



## Sales branches

### Austria

Internorm Fenster GmbH

A-1100 Wien · Hebbelplatz 5  
Tel.: +43 (1) 605 72-0 · Fax: +43 (1) 605 72-2125  
E-Mail: wien@internorm.com

A-4061 Pasching · Kremstal Straße 5  
Tel.: +43 (7229) 770-2440 · Fax: +43 (7229) 770-2433  
E-Mail: linz@internorm.com

A-5020 Salzburg · Himmelreich 1  
Tel.: +43 (662) 66 32 33-0 · Fax: +43 (662) 66 32 33-2530  
E-Mail: salzburg@internorm.com

A-6020 Innsbruck · Eduard-Bodem-Gasse 1  
Tel.: +43 (512) 36 10 48-0 · Fax: +43 (512) 36 10 48-2625  
E-Mail: innsbruck@internorm.com

A-8502 Lannach · Industriestr. 2  
Tel.: +43 (3136) 825 00-0 · Fax: +43 (3136) 825 00-2829  
E-Mail: lannach@internorm.com

A-9020 Klagenfurt · Dammgasse 10  
Tel.: +43 (463) 452 12-0 · Fax: +43 (463) 452 12-2918  
E-Mail: klagenfurt@internorm.com

### Germany

Internorm-Fenster GmbH

Zentrale Deutschland  
D-93059 Regensburg · Nußbergerstr. 6b  
Tel.: +49 (941) 464 04-0 · Fax: +49 (941) 464 04-22 40  
E-Mail: regensburg@internorm.com

### Switzerland

Internorm-Fenster AG  
CH-6330 Cham · Gewerbestr. 5  
E-Mail: cham@internorm.com

Ausstellung Ostschweiz  
CH-9434 Au · Berneckerstr. 15  
Tel.: +41 (71) 747 59 59 · Fax: +41 (71) 747 59 58  
E-Mail: au@internorm.com

Ausstellung Mittelland  
CH-5502 Hunzenschwil · Römerstrasse 25  
Tel.: +41 (62) 926 07 52 · Fax: +41 (62) 926 07 54  
E-Mail: mittelland@internorm.com

Salle d'Exposition Suisse Romande  
CH-1196 Gland · 11 Chemin de Riant-Coteau  
Tel.: +41 (22) 364 67 33 · Fax: +41 (22) 364 86 22  
E-Mail: gland@internorm.com

### France

Internorm Fenêtres SAS

BP 20073 · Rue d'Artois · Zone Actipolis 2  
F-68392 SAUSHEIM CEDEX  
Tél.: +33 (3) 89 31 68 10 · Fax: +33 (3) 89 61 81 69  
E-Mail: sausheim@internorm.com

### Italy

Internorm Italia S.r.l.

I-38121 Gardolo (TN) · Via Bolzano, 34  
Tel.: +39 (461) 95 75 11 · Fax: +39 (461) 96 10 90  
E-Mail: italia@internorm.com

### Slovenia

Internorm okna d.o.o.

SLO-1000 Ljubljana · Koseška cesta 8  
Tel.: +386 (1) 581 92 55 · Fax: +386 (1) 581 92 57  
E-Mail: internorm.okna@siol.net

### Czech Republik

Internorm-okno, s.r.o.

CZ-162 00 Praha 6 · Na Okraji 439/46A · Veleslavin  
Tel.: +420 235 09 04 41-43 · Fax: +420 235 09 04 40  
E-Mail: internorm@internorm.cz

### Slovakia

Internorm s.r.o.

SK-915 01 Nové Mesto nad Váhom · L' . Podjavorinskej 10  
Tel.: +421 (32) 77 12 777 · Fax: +421 (32) 77 12 784  
E-mail: office@internorm-okna.sk

### Hungary

Internorm Ablak Kft.

H-2045 Törökbálint · FSD Park 2.  
Tel.: +36 (23) 531-290 · Fax: +36 (23) 531-299  
E-Mail: internorm@internorm.hu

### Croatia

Internorm prozori d.o.o.  
E-Mail: internorm.prozori@zg.t-com.hr

### Romania

www.ferestre-internorm.ro

### Great Britain

Internorm Windows UK Ltd

Unit D · Colindale Business Park  
2-10 Carlisle Road · NW9 0HN, London  
Tel.: +44 (0) 208 205 9991 · Fax: +44 (0) 208 905 8744  
E-Mail: office@internorm.co.uk

# Internorm manual

INSTRUCTIONS

CARE

MAINTENANCE

GUARANTEE

Your personal  
order number

Date	Stamp, Signature

# Internorm®

MY WINDOW INTO THE FUTURE

# Internorm®

MY WINDOW INTO THE FUTURE

# Internorm®

**10**

year-warranty

- No unnatural colour changes or cracked surface for white window and door profiles made of UPVC, with the exception of mitre cracks.
- No unnatural colour changes or cracked inside surfaces for foil-coated window and door profiles made of UPVC, with the exception of mitre cracks.
- No unnatural colour changes or cracked surfaces for anodised or powder coated window and door profiles made of aluminium.
- No condensation between the panes of insulating glass.
- Of the function of the material compound timber, thermal foam and aluminium profiles for all Internorm timber/aluminium window systems in accordance with the Internorm installation and maintenance guidelines.
- Of the function of glueing and sealing of insulation glass panes with the window profiles for all Internorm timber/aluminium window systems in accordance with the Internorm installation and maintenance guidelines.
- The glue connection of glued Georgian/feature bars.

**5**

year-warranty

- PVD coated door handles are guaranteed against corrosion if there is no mechanical damage.
- No unnatural colour changes or surface cracks in door fillings. There is no guarantee for changes in the surface appearance as a result of dirt.

**3**

year-warranty

- No unnatural colour changes or surface cracks for roller shutter profiles made of UPVC.
- No unnatural colour changes or cracked surfaces for anodised or powder coated roller shutter and blind profiles made of aluminium.
- The function of the window or door fittings is guaranteed, provided that the Internorm installation and maintenance guidelines have been adhered to.

**30**

year-warranty

Furthermore Internorm guarantees safe-guarding that Internorm products can be repeatedly serviced by our experts in such a fashion (original parts not obligatory), to retain their full function for a period of 30 years.  
However, this presupposes that the frame construction (frame and sash) is not damaged. The 30-year period starts from the production date. The services required to maintain the functionality, including the materials required, labour etc. will be invoiced according to the currently valid rates.

**Congratulations!**

You have selected an Internorm product of the very highest standard in terms of quality, technical perfection and design. It is supported by the advanced skill of more than 82 years of experience in window construction. By purchasing Internorm you have chosen leading brand reliability.

<b>1. Product liability and warnings</b>	<b>2</b>
<b>2. Operation</b>	<b>8</b>
2.1. Windows and French doors	8
2.2. Sliding, and folding sliding elements	12
2.3. Entrance doors	15
2.4. I-tec ventilation system IV30	22
2.5. I-tec shading	26
<b>3. Setting and adjustment possibilities</b>	<b>30</b>
3.1. Concealed hardware	30
3.1.1. VV Hardware	30
3.1.2. I-tec Locking	34
3.2. Exposed hardware	37
3.3. Further hardware versions	40
3.4. Entrance doors	51
3.5. Window shutter adjustment	67
3.6. Insect protection	68
<b>4. Cleaning, care and maintenance</b>	<b>69</b>
4.1. General information	69
4.2. Hardware	69
4.3. Cleaning tips – glass surface	70
4.4. Seals	71
4.5. UPVC surfaces	72
4.6. Wood surfaces for timber/aluminium elements	72
4.7. Anodised or powder coated aluminium surfaces	72
4.7.1. Requirements for the cleaning process of aluminium surface	73
4.7.2. Cleaner for anodised aluminium surfaces	74
4.7.2.1. General cleaner for anodised aluminium surfaces	74
4.7.2.2. Conservation agent for anodised surfaces	75
4.7.3. Cleaner for powder coated aluminium surfaces	75
4.7.3.1. General cleaner for powder coated aluminium surface	76
4.7.3.2. Conservation agent for powder coated aluminium surfaces	76
4.8. Cleaning advice for stainless steel	77
4.9. Care and maintenance of I-tec ventilation system	77
4.10. Special warning regards timber/aluminium elements	78
<b>5. Comfort</b>	<b>79</b>
<b>6. Ventilation</b>	<b>80</b>
<b>7. Warranties</b>	<b>83</b>
7.1. General information	86
7.2. Fitting instruction	87
7.3. Technical limitations of the warranty	88
7.4. Information on CE labelling	89

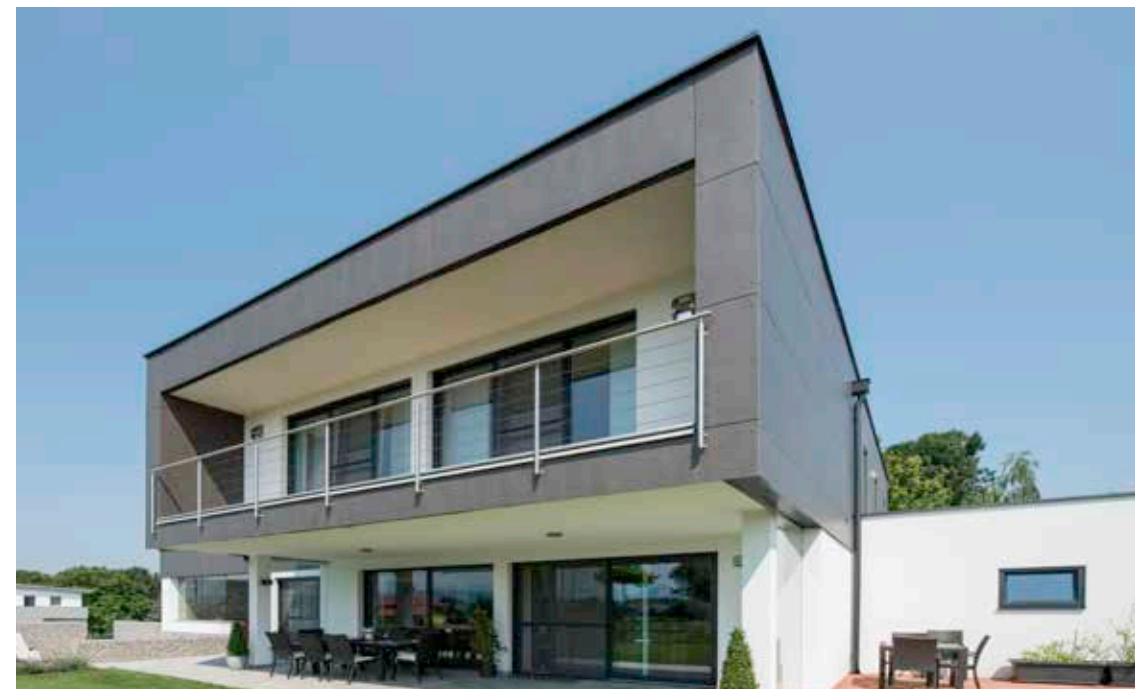

**ENJOY THE BENEFITS OF INTERNORM PRODUCTS!**

You have made a wise decision by choosing Internorm quality products.

Thank you again for putting your trust in Internorm. If you have any other questions which are not answered in this handbook, please call us on

**020 8205 9991**

Or send us an E-Mail: office@internorm.co.uk  
For further information: www.internorm.co.uk

## 1. PRODUCT LIABILITY AND WARNINGS

### General Information

Internorm windows, doors, sun protection elements and accessories are high-quality products.

In order to ensure their lasting serviceability and durability as well as to prevent personal and material damage, their professional service and maintenance is essential. In this manual you will find basic information to this end. Disregard of this information can lead to exclusion from warranty and product liability claims. Functional impairments or wear and tear of parts, which usually occur within the limits of normal and proper use, are not covered by warranty obligations. Excluded are also any damage which is the result of improper handling, unintended use of the product and attempts of repair by unqualified persons.

The intended product use of windows and doors includes the opening and closing of sashes fixed at vertically installed elements. When closing the sash, the counterforce of gaskets has to be overcome. All other kinds of use do not correspond with the intended use.

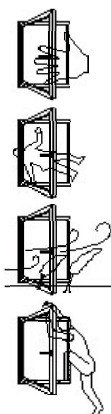

### **Please consider the following points:**

The opening gap between the sash and the frame can pose a risk of injury through jamming.

When the window is open, there is a risk of falling down - great danger for children.

When the window sash is open, there is a risk of injury through the effects of wind and storms.

Avoid additional load on the sash (not intended as coat hanger or stepladder).



Please take care that no objects can get between the sash and the frame and that no objects are jammed when closing the window.



Please avoid sashes being pressed against window frames contrary to normal use or in an uncontrolled manner (e.g. through wind load), which may result in damage of hardware, destruction or consecutive damage of hardware, frame materials or other parts of the window or door.



In case of wind and draught, window and door sashes must be closed and locked.



Opened and tilted sashed do not meet the requirements for impermeability of joint seals, driving rain impermeability, sound insulation, heat insulation and anti-burglary protection.



Closed windows do not meet the requirements for airing necessary for maintaining good health and heating. If the windows are used for airing rooms, this has to be done on a regular basis implementing proper airing habits.



Normal glass does not meet any requirements for increased risk of breakage, anti-burglary protection and fire protection.



Normal glass can break easily. The resulting sharp glass edges and glass splinters pose a risk of injury.



Entrance doors that have not been locked properly (e.g. locked only via the latch) do not meet the requirements for anti-burglary protection.



Security related hardware has to be checked regularly regarding its tight fitting and corrosion. If required, fixing screws must be tightened or parts have to be exchanged.

## 1. PRODUCT LIABILITY AND WARNINGS

Internorm®



Please store separately delivered glass in a dry place --> Moisture destroys the edge area.



All window and door elements which are designed to be opened, closed and locked have to be operated at least once a month to avoid damage through „inoperative wear and tear“ (especially corrosion and stiffness).



During construction works many mechanical, climatic and chemical strains have an effect on windows and doors. Consequently protect the construction elements by covering them and ensure proper aeration in order to regulate humidity.



Please protect timber/aluminium elements during construction works from humidity, rain and snow. There are openings for vapour pressure compensation of the profiles in between the aluminium and timber profiles. Please protect these joints from humidity until the building connection is established.



Please use appropriate adhesive tapes for protecting the surfaces. The adhesive tapes have to be compatible with timber, plastic and aluminium surfaces. The adhesive tapes must be removed as soon as possible, when they are not needed any longer.



Wet mortar, concrete and plastering materials can cause massive permanent stains - especially with timber type larch. This is caused by a chemical reaction with the timber components (tannic acid). Protect your timber surfaces during construction works with suitable masking materials.



Should despite careful handling, any staining remain on the construction elements, these must be removed promptly and completely using mild detergents.



Please avoid formation of too much humidity (max. 50 % at 20 °C). It leads to consecutive damage like swelling of timber parts, damage of painted surfaces (door panels), deformation of construction parts, formation of mould and an unhealthy living climate. The effects of too much humidity have to be avoided especially also during particular construction periods (inside plastering or screed work).



Alkaline leachates from the facade and walls can cause irreversible damage on powder-coated and anodised aluminium surfaces. To avoid this, the window and door frames have to be cleaned and conserved in time.



Insect excrements, pollen, soot particles, iron dust (wear from rail tracks) and similar things can, in combination with rain water and intensive UV radiation, cause staining on UPVC surfaces which are hard to remove and cannot be tackled with regular household cleaner. Therefore, the contact time of such stains should be kept as short as possible. The frame profiles have to be cleaned as soon as possible if such stains occur. Protect the affected profiles with suitable means.



Check the pull belts of roller shutters regularly for wear and tear in order to avoid the danger of a roller shutter falling down.



Sharp edges of functional elements can lead to injury when door and window elements are handled wrongly, especially when someone sits or stands partially or fully under an opened sash.



Please take care that for concealed hardware the turn limiter is snapped into place in the bolt in the corner hinge.

## 1. PRODUCT LIABILITY AND WARNINGS

Internorm®



If doors have been fitted with turning hinges, which are screwed into the sash protrusion, the sash has to be protected against „reveal impact“ through a stopper fitted on site. Otherwise there is a risk of damage due to the enormous forces which affect the turning hinges



Security construction parts like turn limiters and stay-arms must only be unlocked by qualified personnel in order to adjust or unhinge a sash.



Increased thermal load and heat accumulation on the glass can lead to spontaneous glass breakages. Avoid part-shading of glass which is caused through external sun protection systems. Heat accumulation on the glass results from heat sources (radiator, lights) and during sun exposure from very dark objects which are too near the glass on the inside or outside. Avoid attaching foils and paints to the glass later.



Panel fillings in sound protection versions have insulating glass built into the core. These panels must not be machined in any way (drilling, cutting) and have to be protected from excessive shock and impact forces.



Before using the windows, security related hardware and hardware accessories have to be tested for safe functioning (e.g. lockable window handle, turn stop, rebate and cleaning stay-arm security, turn and opening limiter, etc.) and if necessary have to be adjusted by qualified personnel. Nonobservance of this can lead to damage on property and persons.



With the all-glass attachment sash GF, the security clamps at the bottom and top must not be removed or changed.



Protect material surrounding the window or door element which is not waterproof (especially cills or timber floors) from possible condensation

### Wrong handling

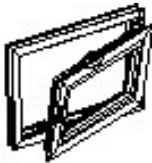

If the window handle is brought into tilt position when the window is open, the sash will loosen from the top locking mechanism. In order to avoid injury or damage, please proceed as follows:



Keep the window handle in tilt position and press the sash onto the frame at the side of the stay-arm, and turn the handle (90°) into turn position.

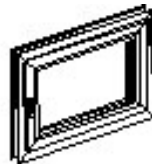

Then close the window and turn the window handle into locking position (turn 90°). Now you can tilt or open the window sash again without any problems.



## 2. OPERATION

### 2.1. Windows and window doors

#### Tilt-turn version

The sash can be turned via positioning the handle horizontally and tilted via positioning the handle vertically.

Tilt window

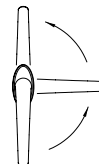

Open window turn position

Close and lock window

---

#### Turn version

Positioning the handle vertically upwards is not possible.

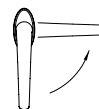

Open window turn position

Close and lock window

---

#### Tilt version (KGO)

The handle is mounted in the centre at the top. Positioning the handle vertically upwards is not possible.

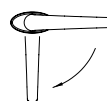

Close and lock window

Open window, tilt position

---

#### Tilt version (KG)

The sash can be tilted by positioning the handle vertically and horizontally.

Tilt window

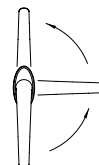

Tilt window

Close and lock window

## 2. OPERATION

# Internorm®

### Fanlight version (KAZ)

The sash is operated via a pull rod. When the pull rod is pressed down, the sash is brought into tilt position.

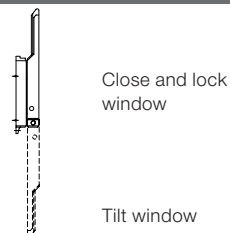

### Fanlight version (KAK)

The sash is operated via a crank handle. For opening the sash the crank handle is taken out of the wall bracket, folded (as shown in the drawing) and positioned into tilt position by turning the crank handle.

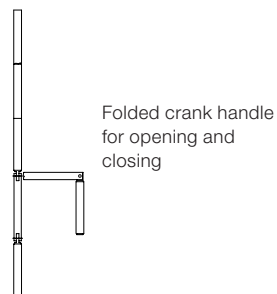

### Lockable turn/turn-tilt door

The door can be turned by positioning the handle horizontally and tilted by positioning the handle vertically.

In this version the drive stroke is locked by the cylinder, i.e. the handle cannot be operated any longer. The door can be locked in the closing as well as in the tilt position.

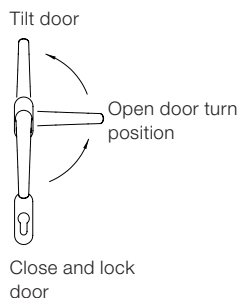

### Multi-point locking turn door

By pressing the lever handle down, the latch is drawn back and the door can be opened. The lever handle bounces back. For locking the door, the lever handle must be pressed upwards by 45°, all the locking elements lock and the profile cylinder can be locked. For opening the door, the cylinder must be operated first and only then the lever handle can be pressed down and the door can be opened.

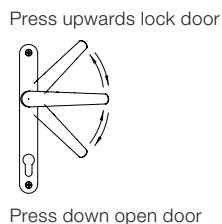

## 2. OPERATION

Internorm®

### Deadbolt lock turn door

By pressing the lever handle down or operating the cylinder (contrary to locking direction) the latch is drawn back and the door can be opened. The lever bounces back. The door is locked with the bolt, which is operated via the locking cylinder (extending the bolt). The lever can also be operated when the lock is locked.

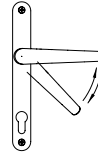

Press down, open door

---

### Side entrance door

By pressing the lever handle down or operating the cylinder (contrary to locking direction) the latch is drawn back and the door can be opened. The lever bounces back. The door is locked via the bolt and the locking pins, which are operated via the locking cylinder (two full turns).

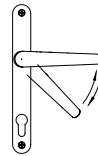

Press down, open door

---

### 3 sash window without transom (model 50)

In order to avoid damage of the sashes, the opening sequence had to be adhered to:

**For opening:** First both end sashes, then centre sash!

**For closing:** First the centre sash, then both end sashes!

## 2. OPERATION

# Internorm®

### Attachment sash composite window

The locks of the attachment sash are only accessible when the window sash is open. The locks are positioned on the inside of the drive between the window sash and the attachment sash. Take out locking latches by 90° and open attachment sash. Please take care that all locking latches have been locked into place before locking the sash again.



By closing the vent slots with a grid you can prevent insects entering in summer.



Open up the vents again in winter to ensure good ventilation. This should help prevent misting up and condensation.



### 2.2. Sliding and folding sliding elements

#### Sliding windows

For sliding operation the handle is turned horizontally, then the sash is positioned parallel and can be slid sideways.

For tilt operation the handle is turned 180° upwards.

Tilt window

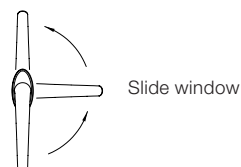

Close and lock window

#### Sliding tilt door

In order to be able to open the sash, the handle is brought into the sliding release position (45° position). The sash is positioned parallel and can be slid in both directions. When the sash is closed, this handle position acts as anti-lockout device (sash does not snap in when closed). If you want to bring the sliding sash into tilt position, the handle is turned to horizontal. The sash cannot be slid and is locked at the bottom. In order to close and lock the door, the sliding door handle is turned vertically downwards.

Sliding release anti-lockout device

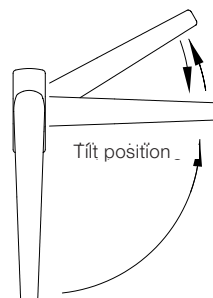

Closing position and locked

#### Parallel sliding window/door

Turn the handle horizontally for sliding function, afterwards position the sash parallel by pulling the handle and slide to the side. For closing, push the sash so far until it swerves back into the locking position again.

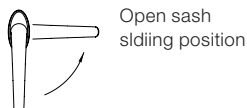

Close and lock sash

## 2. OPERATION

# Internorm®

### Folding sliding door

Operation of sashes used as passage is the same as for turn and turn-tilt versions for windows and window doors.

Folding sequence:

When folding at least 3 sashes on one side, a folding sequence control is installed on the top of the sash, which determines the folding sequence when opening.

When closing, folding sequence is in reverse order.

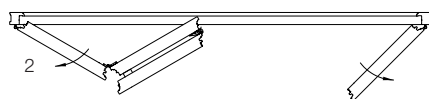
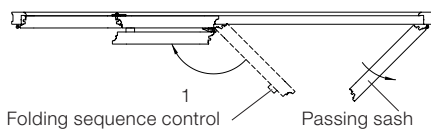

### Lift and slide door

For opening and sliding of the sash, turn the handle completely down.

The sash can be lowered either in the locking position, airing position or any other open position. It is then secured against sliding.

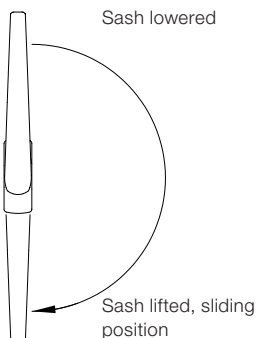

Turn handle down, sash is lifted:  
=sliding position

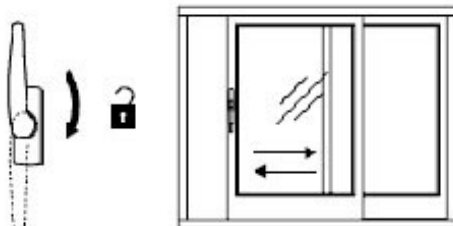

## 2. OPERATION

# Internorm®

Sash lowered at 11 mm opening:  
= secured airing position

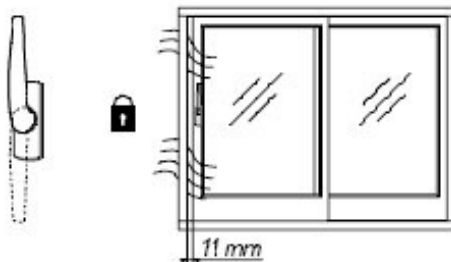

### Side adjustment deadbolt

To avoid collisions of the deadbolt with the drive, these can be adjusted at the side.

(only applies to model C)

Loosen both screws, move deadbolt in parallel and tighten screws again.



### 2.3. Entrance doors



Only a locked door will provide security!

#### Latch deadbolt lock



##### Locking the door

Door is closed. One full turn with the key (single rotation) in locking direction → deadbolt extends.

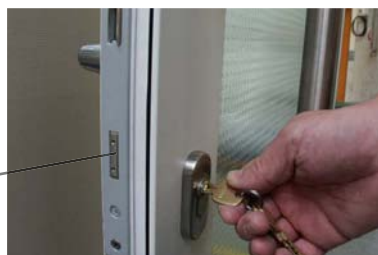

##### Unlocking the door (from the locked position)

Door is open. One full turn with the key (single rotation) against locking direction → deadbolt retracts.



##### Opening the door (from the unlocked position)

**With lever handle:** Push lever handle down → latch retracts, open the door.



##### Opening the door (from the unlocked position)

**No lever handle:** Turn key against locking direction up to turn stop. Latch retracts. Press door sash against opening direction at the same time → Latch is released.



### Multi-point lock



Main bolt



Bolt with extra rotary bolt

### Locking the door

**Door is closed. Two full turns with the key (double rotation) in locking direction** → the main bolt and the bolt with extra rotary bolt units above and below the main bolt extend.

### Unlocking the door (from the locked position)

**Door is closed.** Two full turns with the key against locking direction  
→ the main bolt and the bolt with extra rotary bolt units retract.

### Opening the door (from the unlocked position)

→ see latch deadbolt lock (previous page).

### Deadbolt lock



#### Locking of door

**Door is closed.** One full turn of the key (single rotation) in locking direction → the deadbolt extends.



#### Unlocking the door (from locked position)

**Door is closed.** One full turn of the key against locking direction → the deadbolt retracts.

#### Opening the door (from an unlocked state)

**With handle lever** – press lever down → latch retracts, open door.

### Aluminium window shutters



Ensure that open window shutter sashes are correctly fixed in the wall holders. Close window shutters when storms (wind speeds over 35 mph). Otherwise occurring load can damage or destroy hardware parts. This can lead to subsequent damage.



#### Open and close shutter

In order to open, engage the latch of the closing lever and turn lever. Then turn shutter open, until it engages in the wall shutter catch.

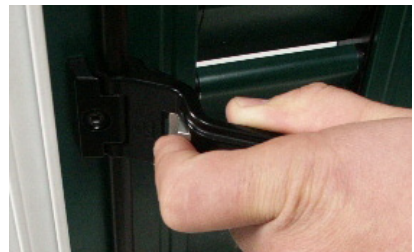

In order to close the shutter, press down the shutter catch and turn the shutter inwards. Then turn locking lever until the turn bar lock engages by itself.



### **Operation of the hinge locking mechanism**

When closing the shutter, press the hinge locking mechanism and turn shutter inwards. When opening the shutter, the hinge locking mechanism engages automatically. The shutter can be unhinged or hinged at approx. 15° opening angle.

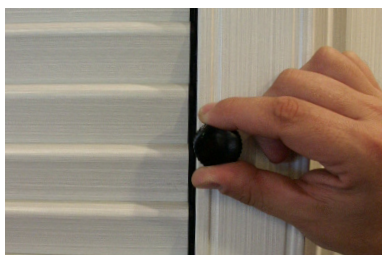

### **Adjustment of slats**

Adjustable slats are adjusted via a thumbscrew. Loosen it and move it up or down until the slats are in your desired position. After reaching this position, carefully tighten the thumbscrew again.

### Roller shutters



In order to **pull up** the roller shutter, pull the belt downwards, the belt is rolled up automatically.

In order to **lower** the shutter, carefully let the belt slide through your hand.

---

### Blinds



As precautionary measure (accident prevention) the ball chain connector releases the ball chain as soon as it is loaded with more than 5 kg of force.

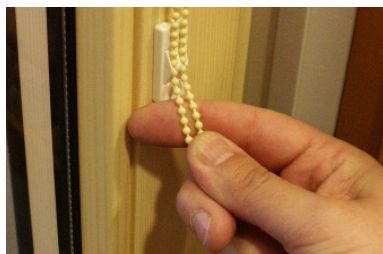

1. To **lift, lower** or **turn** blinds, unfasten ball chain from chain holder

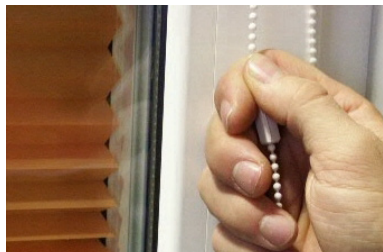

2. Then bring the blinds into the desired position by carefully pulling downwards on the ball chain, finally re-fasten the ball chain in the chain holder

### Insect protection

#### Pull-down flyscreen

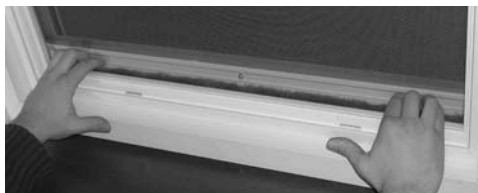

##### **Closing the pull-down flyscreen**

Pull screen down with both hands until it engages in the catch.

##### **Opening the pull-down flyscreen**

###### **From the inside or outside**

Push with both hands down until the catch disengages.

#### Friction fit frame



1. Open the window. Hold the friction fit frame on the plastic clips and put into the frame clearance on the outside. Position the bottom brackets first between the window frame and the gasket.



2. Pull the friction fit frame into the frame clearance so that the top brackets can also be positioned into the window frame by moving the plastic clip up. Afterwards fold the plastic clips down.

### 2.4. I-tech ventilation system IV30

#### Operation

- Phase 0: Stand by
- Phase 1: Whisper mode, 4-6 m³/h
- Phase 2: 8 m³/h
- Phase 3: 23 m³/h
- Phase 4: Turbo mode (ventilation system runs for 1 hour on full load and switches back to the previously set mode automatically).

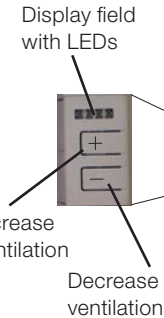

The respective operating phase of the ventilation system is displayed on the display field with green LEDs.

The LED display goes out after 1 minutes and only lights up with the next press of a button.

Phase 4: Press the + button for at least 2 seconds.

Phase 0:  
Ventilator on phase 1 and press the – button for 5 seconds.

#### Illuminated LEDs

Phase 0:	
Phase 1:	
Phase 2:	
Phase 3:	
Phase 4:	

The red LED lights up when a filter change is necessary (display is time-controlled).

To quit display „change filter“: press + button and - button at the same time at least for 5 seconds.

The red LED flashes if there is a defect in the device. Please call customer service.



### **Frost protection device:**

To prevent the danger of the heat exchangers icing up, the ventilation system has been equipped with a frost protection device. The electronic device continuously monitors the extracted air temperature (after the heat exchanger).

If this falls below a certain value, first the speed of the extracted air ventilator is increased and the speed of the fresh air ventilator is decreased.

If after an observation time of 600 seconds no „normal state“ has been achieved, the fresh air ventilator is switched off.

If after a further 600 seconds this has not lead to a normalising of the temperature, the ventilation system is switched off completely.

Only once the temperature sensor has reached its threshold value, the ventilator will start off again automatically at its last set ventilation level.

### **Emergency start-up:**

Starting up the ventilator in cold temperatures (below approx. +5 °C) will be initially prevented by the frost protection device

If you still would like to run the ventilator, please proceed as follows:

Press the – key for 10 seconds, this resets the control. Then select with the + key the required ventilation level.

If the extracted air temperature after 600 seconds has not reached at least the threshold value, the frost protection device will take over again as described above.

### **Pressure conditions in the room when operating ventilator:**

In principle the ventilation control works in such a way that there will be a slight negative pressure in the room (acc. to. DIN 1946-6). However, this will be massively overlaid by the pressure conditions in the building or the pressure and suction conditions due to wind loads.

If you would like to have an open fire place, please be in contact with your chimney sweep. For complete protection when operating open fires, an additional pressure controller might need to be installed in the room.



### Change air filter



Firstly, switch ventilation system to stand by (phase 0)! Otherwise danger of injury due to rotating fan.

4x



Open sash, unscrew middle cover and take cover off.



Pull the sash slightly closed and tilt the cover towards the outside when taking it off.



Take out dirty filters and put new filters back in.  
Put cover back on and screw on.

### Deactivate ventilation system

If you want to deactivate the ventilation system and to close off the air inlet and outlet to avoid possible draughts, you can seal off the air channels with some foil.

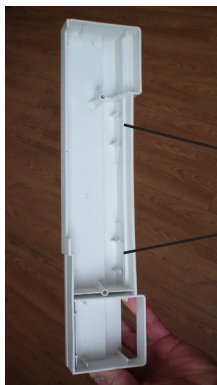

Take off middle cover as when changing filters.

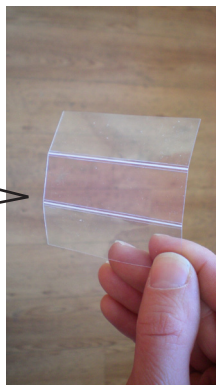

On the inside of the cover you will find two folded pieces of foil.



Unfold the pieces of foil and place them each under the filter mat.



Put the filter mats on top and fasten the cover.

### 2.5. I-tech shading

#### Operation

Key description:

A: Selection key

B: Key Up

C: Key Down

D: Program key

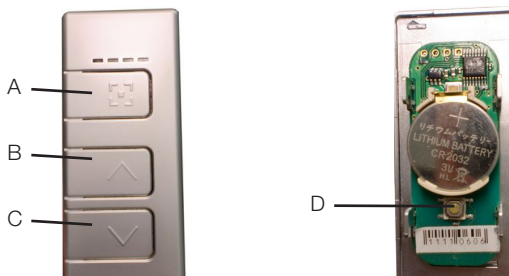

#### Key functions

To move the blind:

By pressing the Up or Down key briefly, the blind moves to the top or bottom end position.

By pressing the Up or Down key briefly, the blind can be stopped.

Adjusting the slats:

By pressing the Up or Down key longer, the slats can be adjusted to the desired angle.

Channel selection:

By pressing the Selection key (key A) briefly, the desired channel can be selected. The selected channel is indicated through continuous lighting up of the LED.

Details on how to program can be found in the enclosed instructions.



To increase the life of the batteries (solar drive), the batteries are equipped with an overheating protection. When it is very hot, this protection will prevent the blind moving up. Moving the blind down and turning the slats is always possible.

### Changing the batteries



First move the blind to the top!  
Open window sash at handle and attachment sash via turning connector.



Turn the black clips on the top and you can take out the blind to the bottom!



Undo the connector between battery and circuit board in order to remove the old battery.

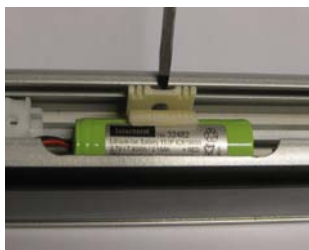

Loosen the battery clip connector and take battery out. Put new battery in, plug connector back in circuit board, watch out that the cable at the side does not touch the rotating shaft.

### Changing the battery on integrated operating unit

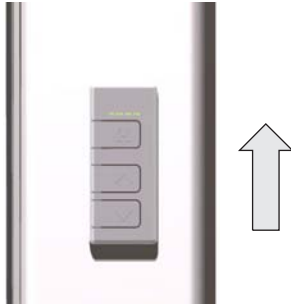

Slide open the cover of the operating unit to the top and take out the operating unit.

Take out battery from the operating unit, insert new one, put cover back on and slide it down.

### Changing the battery on the hand transmitter

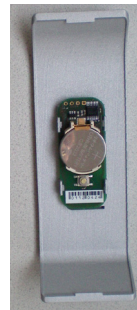

Push the cover at the bottom to the side to open the clip connection.

Take out old battery, insert new one and put cover back on.



Please dispose of used batteries in an environmentally friendly manner!

### Possible adjustments in windows and window doors



Ensure that the adjustment ranges are only used to an extent that does not impair functionality!

#### Height adjustment

Used to raise or lower the sash.

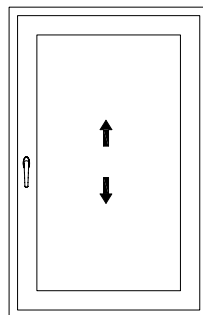

#### Closing pressure adjustment

Used to regulate gasket pressure.

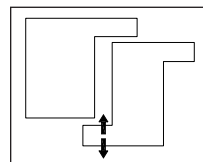

#### Side adjustments

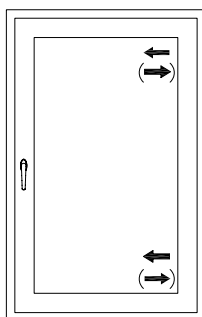

If hinged parts are adjusted in same direction, sash may be adjusted horizontally.

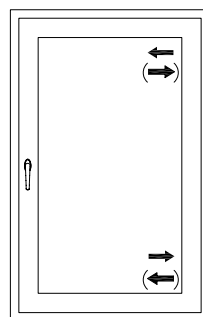

If hinges are adjusted in the opposite direction, this lead to raising or lowering of the sash on the handle side.

## **3. ADJUSTMENTS – ADJUSTMENT POSSIBILITIES**

### **3.1. Concealed hardware**

In order to prevent damage and to retain full functionality of the window, it is recommended to have all adjustment works carried out by authorised personnel.

#### **3.1.1 VV hardware (concealed standard)**

##### **Corner / sash hinge on rectangular window (hinge side - at the bottom)**

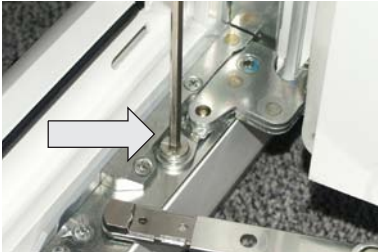

Adjust towards hinge or handle side with 4mm Allen key.



Raise or lower sash with 4mm Allen key, for heavy-duty hardware use torx T25.



Adjust closing pressure with 4mm Allen key.

### 3. ADJUSTMENTS AND ADJUSTMENT POSSIBILITIES

# Internorm®

#### Stay-arm / turn hinge on rectangular window (hinge side - at the top)



Adjust towards hinge or handle side with 4mm Allen key.



For heavy-duty hardware use torx T25.

#### Pressure adjustment on locking parts



##### Security lock

Adjust desired gasket pressure with 4mm Allen key.



##### Standard lock

Pull locking peg (eccentric), turn according to desired gasket pressure, release peg.



### 3. ADJUSTMENTS AND ADJUSTMENT POSSIBILITIES

Internorm®

#### Tilt sash



**Vertical adjustment Version a**  
Tilt sash. Raise or lower sash with 4mm Allen key.



**Vertical adjustment Version b**  
Open sash max. 90°. Raise and lower sash alternately with 4mm Allen key.

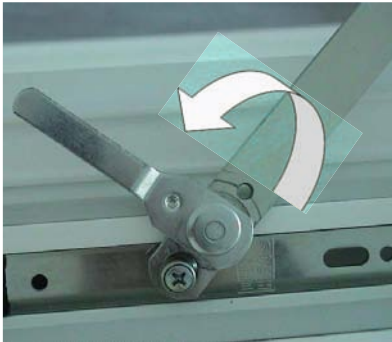

**1. Horizontal adjustment**  
Open rebate stay-arm lock, unhinge rebate stay-arm and bring sash into cleaning position.



**2. Horizontal adjustment**  
Unlock and unhinge cleaning stay-arm.  
**ATTENTION:** Sash is now unsecured and must be secured by a second person! Tilt sash no more than 90°!

### 3. ADJUSTMENTS AND ADJUSTMENT POSSIBILITIES

Internorm®



Loosen fixing screw on tilt hinge with 4mm Allen key.

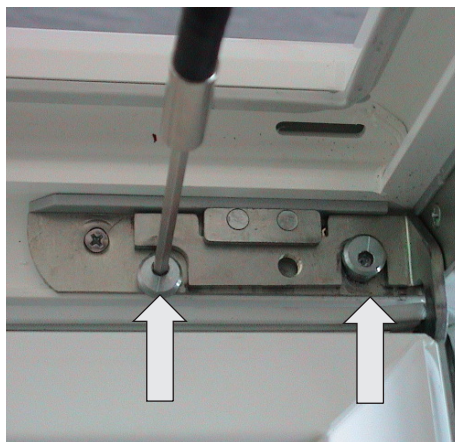

Turn security bolt on both tilt hinges with 5mm Allen key by 180°.

**ATTENTION:**

Sash is no longer secured against unhinging! Danger of falling!

Adjust sash horizontally and carry out all steps again in reverse order.

### 3. ADJUSTMENTS AND ADJUSTMENT POSSIBILITIES

Internorm®

#### 3.1.2 I-tech locking (concealed flap locking)

##### Corner / sash hinge on rectangular window (hinge side - at the bottom)



Adjust towards hinge or handle side with 4mm Allen key.



Raise or lower sash with 4mm Allen key.

##### Stay-arm / turn hinge on rectangular window (hinge side - at the top)



Adjust towards hinge or handle side with 4mm Allen key.

##### Catch at doors



Adjust the catch with 3mm Allen key.

### 3. ADJUSTMENTS AND ADJUSTMENT POSSIBILITIES

Internorm®

#### Tilt hinge

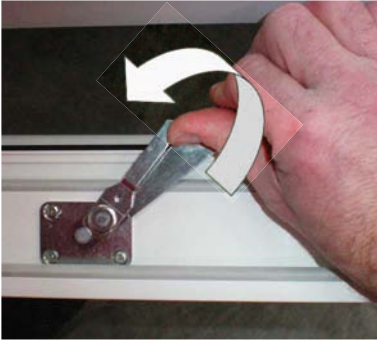

Open rebate stay-arm lock, unhinge rebate stay-arm and bring sash into cleaning position.



Raise and lower sash with 4mm Allen key.

If the height adjusting screw cannot be accessed in the cleaning position, the cleaning stay-arm has to be unhinged additionally as well.



**ATTENTION:** Sash is now unsecured and must be secured by a second person! Tilt sash no more than 90°!



Open cleaning stay-arm lock with slot screw driver and unhinge cleaning stay-arm. **Secure sash!!**

### 3. ADJUSTMENTS AND ADJUSTMENT POSSIBILITIES

# Internorm®

#### Maintenance of I-tech locking

Once per year all movable hardware parts have to be lubricated with acid-free oil or grease!

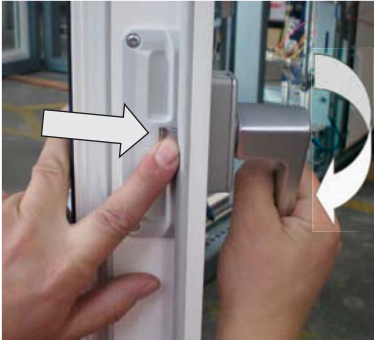

Open sash, press the rocker switch on the drive for the safety device and bring handle into locking position. This opens the locking latches.



If necessary grease sliding parts.

All hinge joints on all top and bottom hinge parts have to be greased.



1

2



3

4

5

6

#### 3.2. Exposed hardware

For some adjustment works possible covering caps have to be removed first.

#### Sash hinge and corner hinge (hinge side - at the bottom)

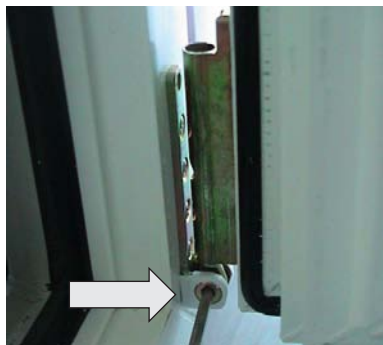

Adjust towards hinge or handle side with 4mm Allen key.



Raise or lower sash with 4mm Allen key.

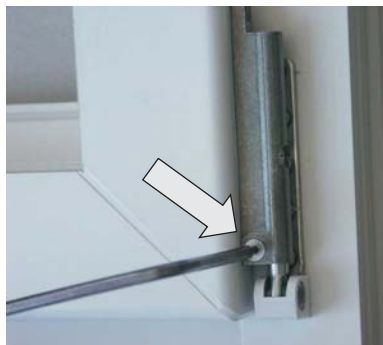

Adjustment of turn limiter with 2.5mm Allen key, if right-handed - with sash closed, if left-handed - with sash open.



### 3. ADJUSTMENTS AND ADJUSTMENT POSSIBILITIES

# Internorm®

#### Stay-arm and turn hinge on rectangular window (hinge side - at the top)

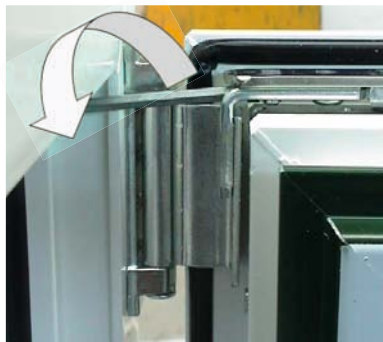

Adjust towards hinge or handle side with 4mm Allen key.



#### Closing pressure adjustment in stay-arm:

Bring sash into tilt position, adjust closing pressure with 4mm Allen key and close sash again.

#### Tilt sash



#### 1. Vertical adjustment

Unlock rebate stay-arm and unhinge, then position sash carefully in window reveal.

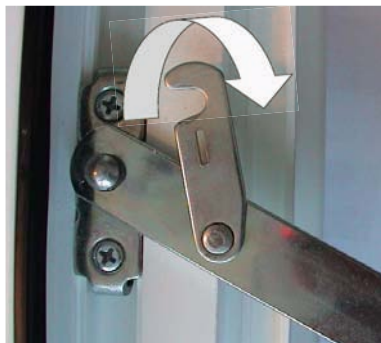

#### 2. Vertical adjustment

Unlock cleaning stay-arm and unhinge. **ATTENTION:** Sash is now unsecured and has to be secured by a second person!

### 3. ADJUSTMENTS AND ADJUSTMENT POSSIBILITIES

Internorm®

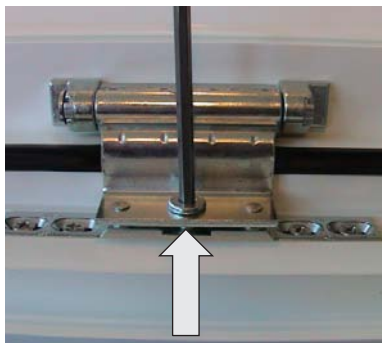

Raise and lower sash with 4mm Allen key.

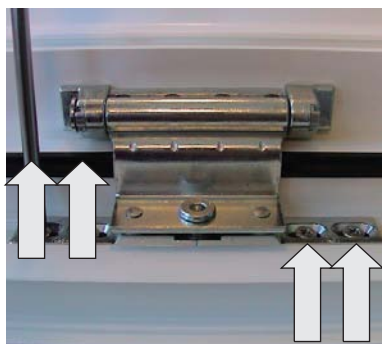

#### **Horizontal adjustment**

Unhinge rebate stay-arm and cleaning stay-arm, as described above. Loosen screws with screwdriver, adjust sash horizontally and tighten screws again. Hinge the cleaning and rebate stay-arm again and lock.



#### 3.3. Further hardware versions

##### Fanlight hardware

###### Closing pressure adjustment

Remove covering cap towards the front. Loosen screw at bottom with 4mm Allen key, adjust pressure with SW14 flat spanner and tighten screw again.

Measures to adjust sashes, as described in previous chapters.

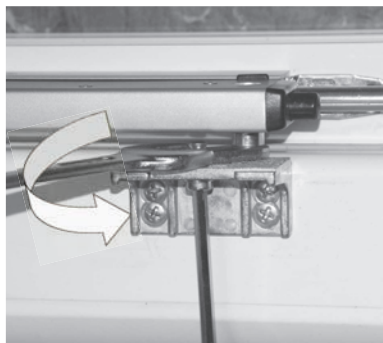

###### Horizontal and vertical adjustment

In order to be able to separate the stay-arm from the bracket, first tilt the sash. Then press the safety knob on the stay-arm, pull stay-arm upwards off the bolt and bring sash in secure position.

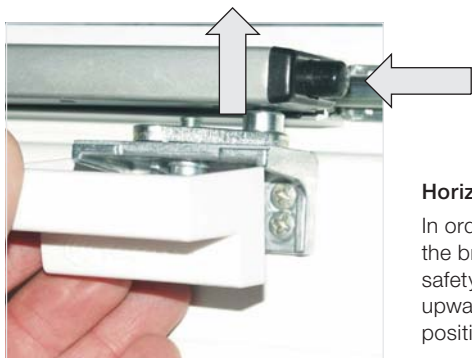

To be able to bring sash into cleaning position (open it completely), undo locking mechanism on side-mounted safety stay-arms.

Further measures for sash adjustment, as described in previous chapters (tilt sash).

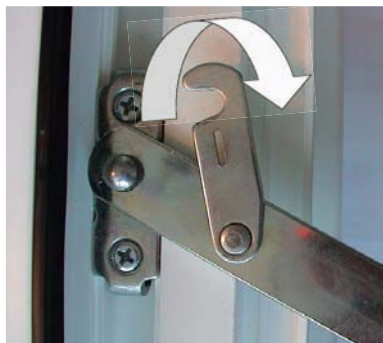

### 3. ADJUSTMENTS AND ADJUSTMENT POSSIBILITIES

Internorm®

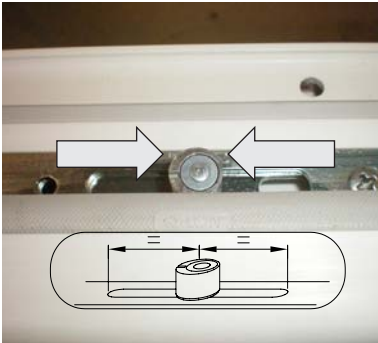

If a bolt of the fanlight hardware engages with the sash hardware, it is absolutely important to centre the locking bolt of the sash hardware which might have been slid to the side by accident, otherwise the sash cannot be closed.

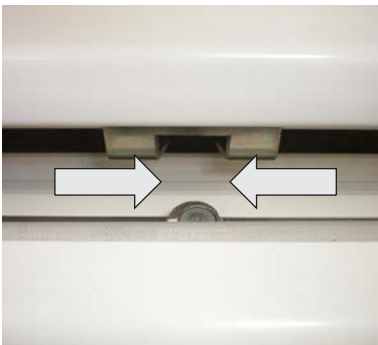

When closing the sash, the bolt of the fanlight hardware has to engage with the locking bolt again.

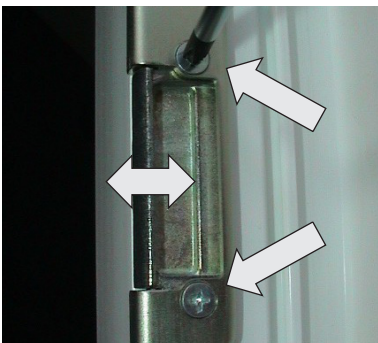

#### Multi-point lock and latch/spring-bolt lock

##### Closing pressure adjustment

Slightly loosen screws with screwdriver. Move locking plate insert and tighten screws again.

Measures for sash adjustments, as described in previous chapters.

### 3. ADJUSTMENTS AND ADJUSTMENT POSSIBILITIES

Internorm®

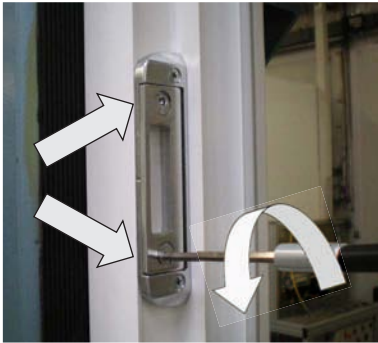

Side entrance door

#### Closing pressure adjustment for latch:

To adjust the closing pressure, adjust the eccentric bolts of the locking element with 4mm Allen key.



#### Closing pressure adjustment for locking bolt:

To adjust the closing pressure, adjust the eccentric bolts of the drive with a torx T15.

### 3. ADJUSTMENTS AND ADJUSTMENT POSSIBILITIES

Internorm®



#### Three-dimensionally adjustable turn hinges

##### Height adjustment

Loosen safety screw for height adjustment with 4mm Allen key. This is only accessible with the sash open.

Then adjust height adjustment screw from below with 4mm Allen key.



Before tightening the safety screw ensure that it attaches to the flattened side of the height adjustment screw, otherwise the thread will get damaged.



##### Side adjustment

The screws for side adjustment are accessible from the reveal (soffit) side when sash is closed and from the rebate side when sash is open.

**ATTENTION:** The screw position indicated by the arrow is fixed to the centre part of the hinge. In order to avoid damage on the thread loosen the other screw before adjustment!

### 3. ADJUSTMENTS AND ADJUSTMENT POSSIBILITIES

Internorm®



Side adjustment is carried out by adjusting both screws on the centre part of the turn hinge with a 5mm Allen key.

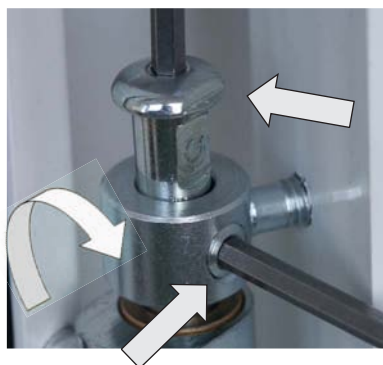

#### **Closing pressure adjustment**

Loosen peg with 4mm Allen key. This is only accessible when sash is open. Pull peg upwards and unhinge sash. Turn parts remaining on the door frame inwards or outwards.

**ATTENTION:** When re-fitting the sash, insert peg so that flattened side faces the safety mechanism.

#### **General advice:**

The adjustment screws are only accessible if first both outer covering caps have been removed upwards or downwards and the central covering cap has been removed towards the front.



#### 3 sash windows without transom, centre sash

##### Height adjustment

First open side sashes. Adjustment is carried out on the support bar of the centre sash with 4mm Allen key.

Adjust side sashes as described in previous chapters.

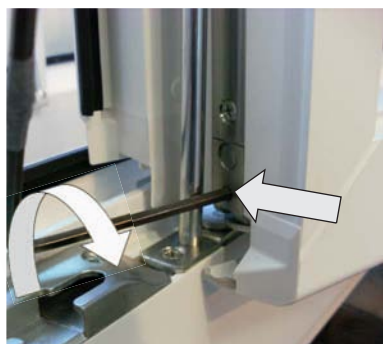

##### Side adjustment corner hinge

Open centre sash so far that Allen screw is no longer covered by support bar. Adjust with 2.5mm Allen key.



##### Side adjustment of turn hinge

Open centre sash. Adjust with 4mm Allen key.

### 3. ADJUSTMENTS AND ADJUSTMENT POSSIBILITIES

Internorm®



#### Closing pressure adjustment in turn hinge

Adjust with 4mm Allen key.

Adjust side sashes as described in previous chapters.

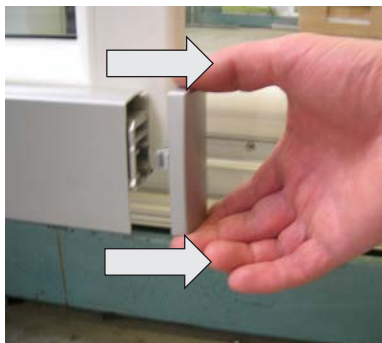

#### Sliding windows

##### Height adjustment

Pull covering cap off sideways from the runner.

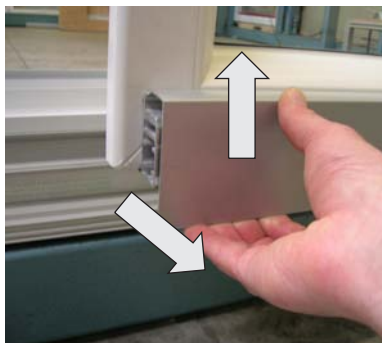

Remove cover profile from the holding clips at the bottom and lift off towards the top.

### 3. ADJUSTMENTS AND ADJUSTMENT POSSIBILITIES

Internorm®

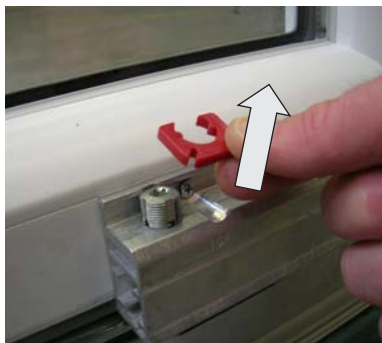

Take off turn stop from height adjustment screw.

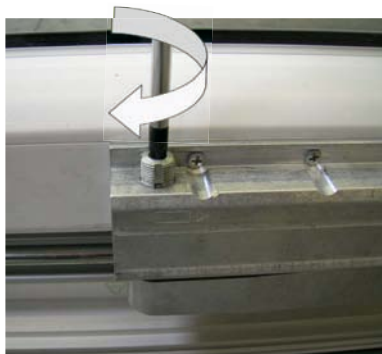

Adjust sash with torx T40.

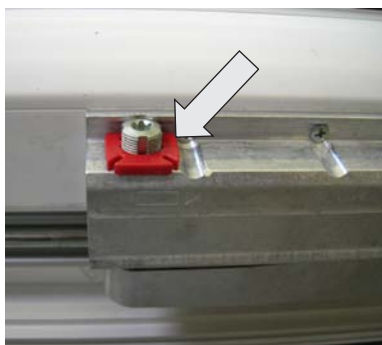

Put turn stop back on.

Attach cover profile again and press on tightly at the bottom. Put side cover caps back on.



### 3. ADJUSTMENTS AND ADJUSTMENT POSSIBILITIES

Internorm®

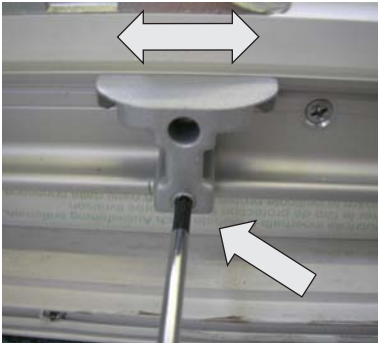

**Bottom stopper for sliding direction „CLOSED“**  
Loosen screw with torx T25, move control block to the side and tighten screw again (max. 3 Nm).

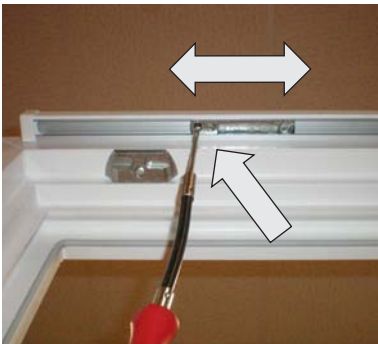

**Top stopper for sliding direction „OPEN“**  
Loosen screw with torx T25, move buffer to the side and tighten screw again (max. 3 Nm)  
Loosen screw with Torx T25, slide stopper to the side and tighten screws again (max. 3 Nm).

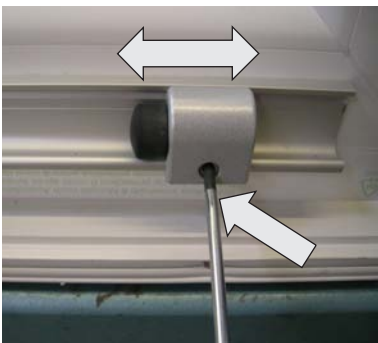

**Bottom stopper for sliding direction „OPEN“**  
Loosen screw with Torx T25 lockern, move buffer to the side and tighten screw again (max. 3 Nm).

### 3. ADJUSTMENTS AND ADJUSTMENT POSSIBILITIES

# Internorm®

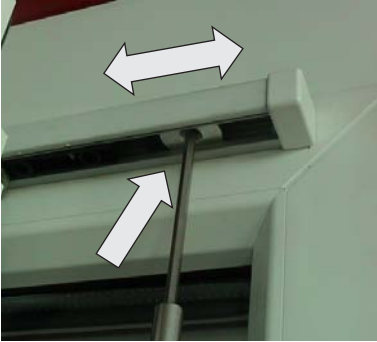

#### Top stopper sliding direction „OPEN“

Additionally to the running rail also for the buffer in the guide rail. Loosen screw with Torx T25, move buffer to the side and tighten screw again (max. 4 Nm).



The stopper buffers serve only to limit the opening and must not be used to stop the sliding sash abruptly!

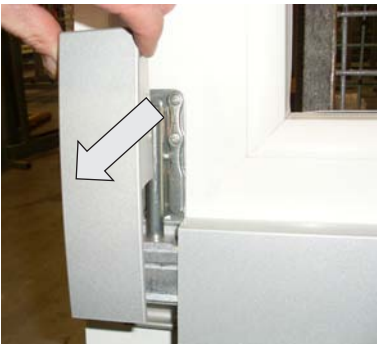

#### Sliding door

#### Height adjustment

Remove covering caps to the front. Remove cover profile and carry out height adjustment as described under „Sliding windows“.

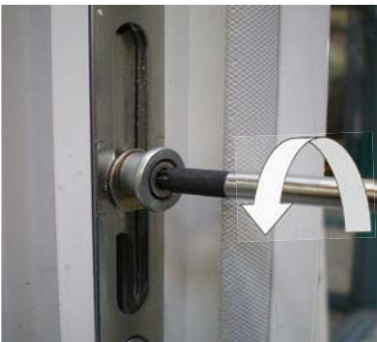

#### Closing pressure adjustment (only with parallel sliding tilt door)

Adjustment of closing pressure with torx T15 on locking bolts.

Further adjustment procedures as described under „Sliding windows“ (see page 43).

### 3. ADJUSTMENTS AND ADJUSTMENT POSSIBILITIES

# Internorm®

#### Maintenance of sliding windows and sliding doors

Once per year all movable hardware parts should be cleaned and greased with acid-free oil or grease!

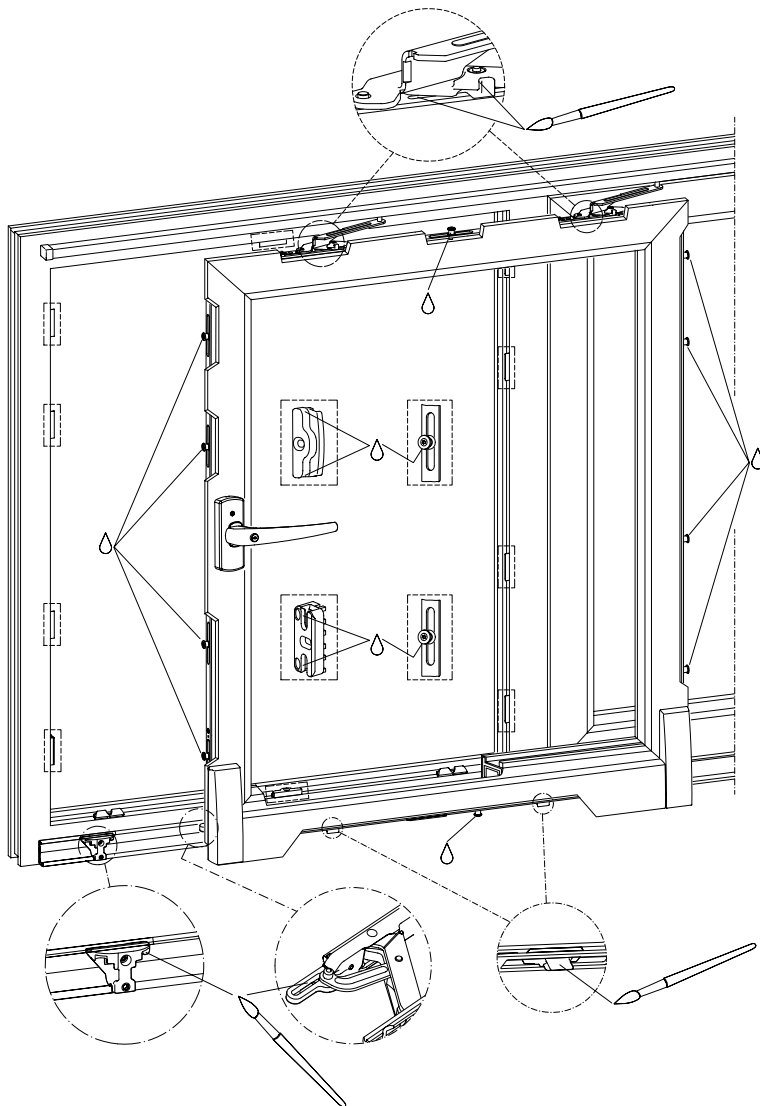



#### 3.4. Entrance doors

##### Aluminium entrance doors

###### **Adjust latch locking part (AT piece):**

It controls the closing pressure from the lock side for latch/spring bolt locks and multi-point locks.

1. Remove both fixing screws.
2. Adjust latch locking part (adjustment via raster).
3. Put fixing screws back in.



### 3. ADJUSTMENTS AND ADJUSTMENT POSSIBILITIES

Internorm®

#### Locking cases for bolts with extra rotary bolts

Controls the lock-sided contact pressure with multi-point locks

##### 1.) AT200, AT300

Adjust both eccentric screws with SW4 Allen key. The locking case changes its position and therefore, the contact pressure changes too.

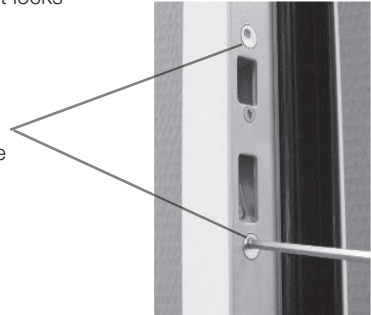

##### 2.) AT400, AT410

First loosen the 3 fixing screws. Then carry out adjustment via the two eccentric screws. Position is shown by marking point on the screws. Afterwards tighten fixing screws.

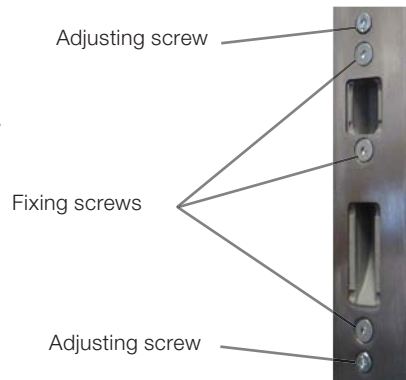

### 3. ADJUSTMENTS AND ADJUSTMENT POSSIBILITIES

Internorm®

#### Electric door opener (ETÖ)

Only for doors with immobile handle (no lever) on the outside.

**Normal position:** Door is kept shut with latch - after electric release the door can be opened by simply pushing against it.

**Day operation (unlocked):** Door can be pushed open at any time. (Described functions only for unlocked doors.)



A door that is merely kept on latch is NOT regarded as locked door. Only the locked door will provide security!

#### Technical data:

10–24 volts (V)

Alternating and direct current (AC/ DC)

Manually switched day operation (unlocking)

Between 11–13V/ DC (direct current) the door opener is also suitable for 100% continuous unlocking --> EE function

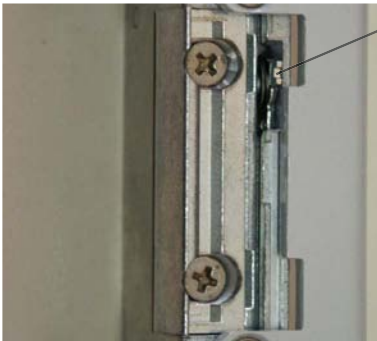

Slider for the change between normal position and day operation



The electric connection has to be carried out exclusively by authorised personnel!

### 3. ADJUSTMENTS AND ADJUSTMENT POSSIBILITIES

# Internorm®

#### Available adjustments for door hinges

Ensure that the adjustment ranges are only used to an extent that does not impair functionality of the door!

#### Height adjustment

Used to raise or lower the door sash.

Is carried out in such a way that the weight of the door sash is evenly distributed between all hinges or washers.

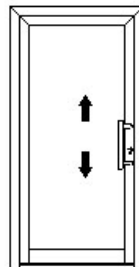

#### Contact pressure adjustment

Used to regulate how far the sash projects and therefore, adjusts the pressure placed on gaskets in the hinge area.

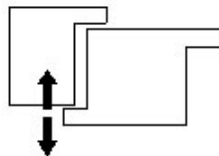

#### Side adjustment

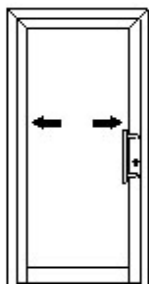

If all hinges are adjusted in the same direction, the rebate clearance (distance from lock mullion to locking plate) can be regulated.

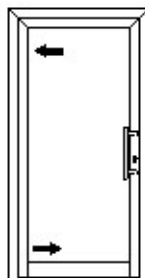

If the hinges are adjusted in opposite directions, this leads to raising or lowering of the door sash on the handle side.

### 3. ADJUSTMENTS AND ADJUSTMENT POSSIBILITIES

Internorm®

#### Adjustment procedures for door hinges in aluminium entrance doors

All adjustments have to be carried out with a 4mm Allen key!



When adjusting three hinges, the centre hinge has to be adjusted in such a way that no tension is created!

**Process:** Remove axle bolt of centre hinge. Adjust door sash with top and bottom hinge. Adjust centre hinge so that the axle bolt can be slid back in without applying force!

#### Height adjustment (-2/+3 mm)



Remove lower cover caps.



Loosen fixing screw..



Bring adjustable support to desired height by turning to the left or to the right.

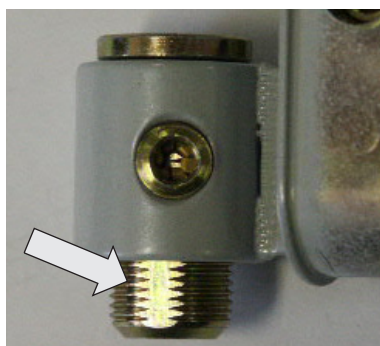

When attaching, always use the milled surface of the adjustable support!



### 3. ADJUSTMENTS AND ADJUSTMENT POSSIBILITIES

# Internorm®

Adjust contact pressure (-1/+3 mm)



Remove UPVC cover.



Loosen both tension screws completely.



Adjust contact pressure in such a way that the gasket in the hinge area is not exposed to too much pressure (sash overlap 14-15mm).

Tighten both tension screws again.

Attach UPVC cover again.

### 3. ADJUSTMENTS AND ADJUSTMENT POSSIBILITIES

# Internorm®

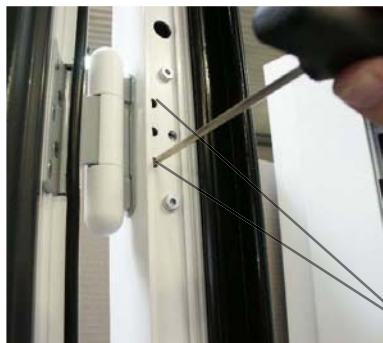

Side adjustment (+/-2 mm)

Loosen both tension screws as far as possible.

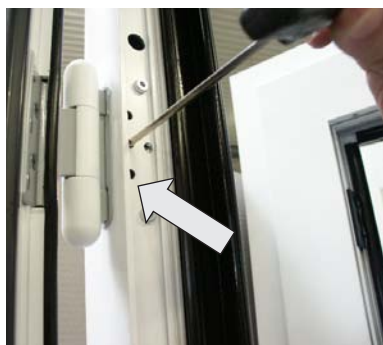

Carry out adjustment, ensure sufficient distance between lock mullion and locking plate (3–4 mm).

Tighten both tension screws again.

Attach UPVC cover again.

### 3. ADJUSTMENTS AND ADJUSTMENT POSSIBILITIES

Internorm®

#### Adjustment process - Concealed door hinge with aluminium entrance doors

The following tools are required for the adjustments:

- Ring spanner no. 13
- Special lift tool (part no.: 34588)
- Allen key SW5
- Torx key 27

With three hinges the middle hinge needs to be adjusted in such a way that no tension is created!

**Three dimensionally adjustable:** All adjustments can be carried out with mounted sash.

#### Height adjustment

Remove the hinge covers (slide towards the top or bottom and pull off).

On hinge side loosen the top 3 screws on all hinges.

Put the lift tool with the long side into the recess of the top hinge and loosen the rest of the screws. Lever the door sash into required position and tighten the screws from the top hinge. Afterwards lightly press against the bottom hinges and tighten.

Adjustment range: -2mm / +4mm

#### Contact pressure

Loosen both hexagonal screws of the hinge and position the hinge protrusion via the short side of the lifting tool.

Afterwards tighten the screws again.

Adjustment range: +/- 1.5mm

#### Side adjustment

Adjust Allen screw on hinge pocket as required.

Groove on hinge protrusion marks the zero position.

Adjustment range: +/- 4mm

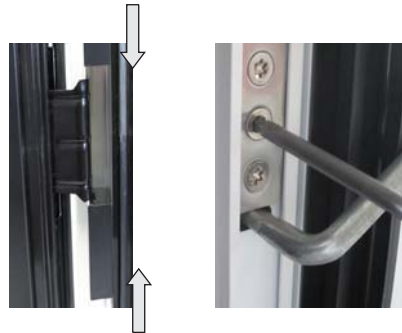



#### Timber/aluminium entrance doors

##### Adjusting the latch closing piece (AT piece)

Regulates the lock-sided contact pressure.

1. Loosen both fixing screws.
2. Adjust latch closing piece (interlocking).
3. Tighten fixing screws again.



##### Adjust bottom and top contact pressure and correct warping on lock side

In the outer rebate area (overlap) on the lock side, there is a tension rod which can be used to correct warping in the door leaf of up to 4mm in both directions.

1. Remove cover cap.



2. Adjust the tension rod with an SW6 Allen key. By turning clockwise the rod is tensioned and the sash ends are bent towards the inside, by turning anti-clockwise the rod is lengthened and the sash ends are bent towards the outside.

**ATTENTION: Do not exceed a torque of max. 35Nm! Danger to damage the door leaf.**

3. Put cover cap back on.

### 3. ADJUSTMENTS AND ADJUSTMENT POSSIBILITIES

Internorm®

#### Adjustment process for door hinges in timber/alu entrance doors with exposed hinges

All adjustments to be carried out with a 4mm Allen key!



Adjust the centre hinge in such a way that no tension is created!

#### Height adjustment (-2/+3 mm)



Remove bottom cover caps.



Loosen fixing screw.



Bring adjustable support to desired height by turning to the left or to the right and correct the other hinges too.



When attaching, always use the milled surface of the adjustable support!

### 3. ADJUSTMENTS AND ADJUSTMENT POSSIBILITIES

# Internorm®



#### Contact pressure and side adjustment

On rare occasions side adjustments or adjustments to the contact pressure of a sash or the gaskets are necessary. Unhinging the door sash is necessary.

#### Unhinge door sash

1. Loosen fixing screw for hinge bolts (top Allen screw) on all hinges.



2. Press hinge bolt out from underneath with a 4mm Allen key . Start at the bottom hinge. Unhinge door sash and put aside.



Be careful when lifting!  
Element weights over 100 KG possible!

3. Put the unhinged door sash carefully on to a pressure-resistant, soft surface (e.g. polystyrene from packaging) to avoid damage!

When leaning it watch for secure standing and also use some padding toward e.g. a wall!



#### Adjust contact pressure

To change the contact pressure of the door sash on the hinge side, the hinge parts on the frame are adjusted when turning. Ensure to adjust the hinges evenly, otherwise the bolts will be subjected to tension and high wear and tear and creaking sounds will result. Both hinge parts always need to be turned full 360° turns inwards or outwards, otherwise they will be positioned wrongly.

### 3. ADJUSTMENTS AND ADJUSTMENT POSSIBILITIES

Internorm®



#### Side adjustment

To carry out side adjustments to the door sash, the hinge parts of the sash need to be turned inwards or outwards with a screwdriver or similar. Through this the position of the door sash is moved to the side. Ensure to adjust the hinges evenly, otherwise the bolts will be subjected to tension and high wear and tear and creaking sounds will result.



#### Hinge door sash

Bring door sash into position and insert hinge bolts again at the bottom, top and centre. It is best to begin with the bottom hinge bolt, then insert the top and the centre one tension-free.



When inserting the hinge bolt ensure the correct orientation. The flattened part needs to be in the area of the Allen screw.

Tighten all Allen screws again and attach cover caps.

### 3. ADJUSTMENTS AND ADJUSTMENT POSSIBILITIES

# Internorm®

#### Adjustment process for door hinges in timber/alu entrance doors with concealed hinges

All adjustments to be carried out with a torx T20 or a 4mm Allen key!



Adjust the centre hinge in such a way that no tension is created! The door panel does not need to be unhinged for adjustments!

#### Mount door panel



The fixing screws in unhinged delivered sashes are screwed into the frame, remove these.

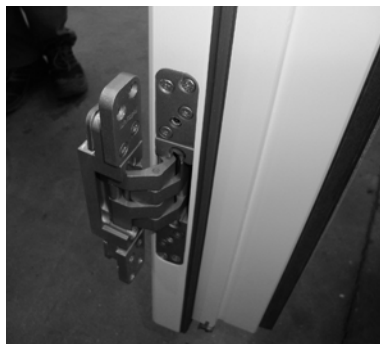

Bring door hinges into a 90° position and lift sash to frame. Attention - high element weights!

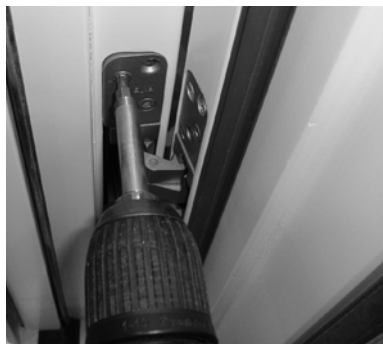

Slide hinges without cross threading into the retaining pockets and fasten each hinge for the moment with a fixing screw.

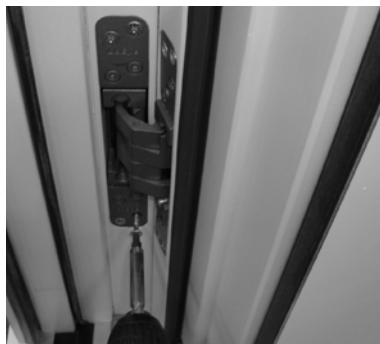

Use the remaining three fixing screws for each hinge.



### 3. ADJUSTMENTS AND ADJUSTMENT POSSIBILITIES

Internorm®

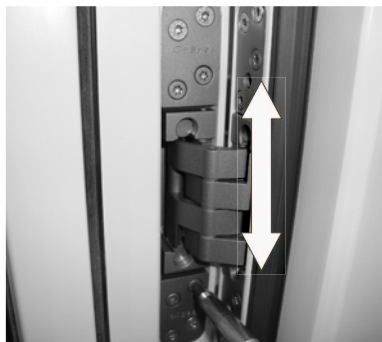

#### Height adjustment

The frame parts of the hinges at the back are equipped with a tooth system. If all fixing screws (4 pieces per hinge) are loosened far enough with a torx T<sup>20</sup>, the sash can be adjusted in the height. Put door at desired height and fasten all fixing screws. Do not subject the hinges to tension to avoid creaking sounds and high wear and tear.



#### Adjust contact pressure

If the fixing screws (4 pieces per hinge) are only loosened slightly, the contact pressure on the hinge side of the sash can be increased or decreased on the height adjusted tooth system. Loosen the screws completely on the centre hinge and carry out the desired adjustments on the top and bottom hinge.. Tighten all fixing screws again.

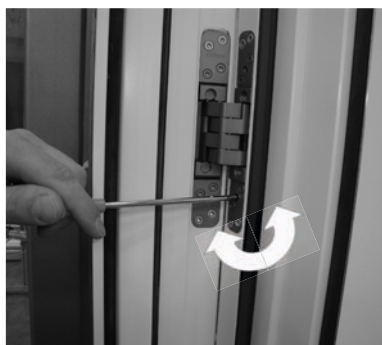

#### Side adjustment

To adapt the gap between frame and sash, the hinge can be adjusted with a 4mm Allen key. For this no fixing screws need to be loosened. Two screws per hinge need to be adjusted. Alternate screws to avoid tension on the hinges.

### 3. ADJUSTMENTS AND ADJUSTMENT POSSIBILITIES

# Internorm®

#### To put lever on and take lever off (AT400)

##### Hoppe lever sets

The new generation of Hoppe lever sets is fitted via an integrated clamping system on the square lever pin.

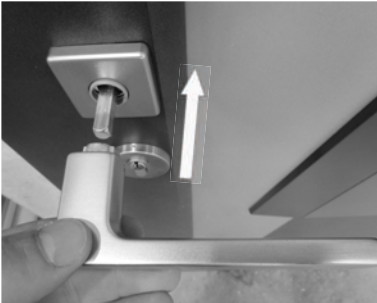

To put lever on:  
Put cover plate in place and slide lever on to pin until it sits tightly. Lever stays in place via preloaded metal spring on lever pin.



To take lever off:  
1. Insert supplied special tool fully into side hole at a slight angle to the cover plate.

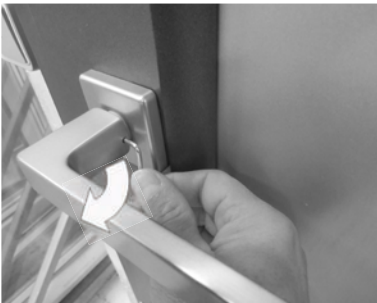

2. Turn special tool by about 90° to loosen clamping system.



3. Pull lever off the pin.

### 3. ADJUSTMENTS AND ADJUSTMENT POSSIBILITIES

Internorm®

#### Valli lever sets

The square lever pin of the new Valli lever set generation engages via an integrated spring clamping system with the sub-structure of the cover plate.

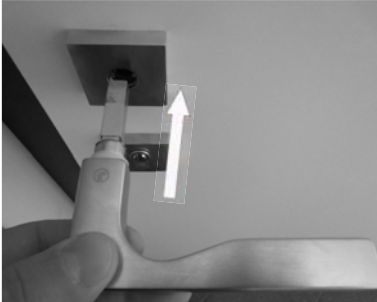

To fit lever:  
Put cover plate in place and insert lever incl. pin into cover plate opening until it engages. Lever stays in place via preloaded spring system.



To take lever off:  
1. Insert supplied special tool from below into cover plate opening.



2. Insert special tool completely. Tool engages, clamping system is loosened.

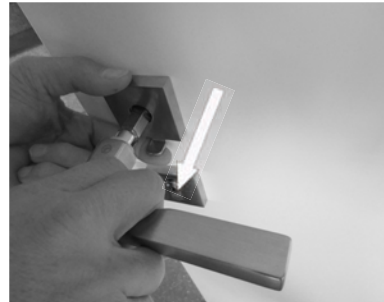

3. Remove lever incl. pin.



#### 3.5. Available adjustments for window shutters

##### **Adjustment of reveal (soffit) depth**

Reveal depth is adjusted via the hinge for reveal depth of 60 - 230 mm.



##### **Side adjustment (hanging of window shutters)**

Side adjustment is carried out via the hinge casings 1.5 and 3mm. Side adjustment via the spindle is only possible with reveal depth 190 - 230 mm.



##### **Adjustment of hinge stabiliser**

The adjustment screw has to be used to press the window shutter against the stopper buffer/wall, then the clamping screw at the top has to be tightened.



#### 3.6. Insect protection

##### Sliding frame

1. For hinging, press the sliding frame so far upwards into the top sliding rail, until the sliding frame can be positioned into the lower sliding rail.



2. Then push the fixing part up and attach it with screws on both sides.



##### Turn frame

Before unhinging, lift the pins and remove them, then the sash can be taken off towards the front.

## 4. CLEANING, CARE AND MAINTENANCE

Internorm products are low-maintenance, easy to clean and to care for. Regular maintenance conserves value and extends the life span of windows and doors. In Austria these necessary measures are documented in the ÖNORM B 5305. This ÖNORM contains criteria to assess the state of a window as well as details and specifications concerning the implementation and instigation of maintenance. If you adhere to the following cleaning, care and maintenance tips, you will be able to enjoy your Internorm products for a long time. In order to retain an immaculate surface, smooth-running hardware and well closing gaskets, please take note of the following care tips.

### 4.1. General information

Do not use cleaning products of unknown composition. If you are uncertain about the effects of a cleaning agent, test it on an inconspicuous, concealed part. Please be aware that cleaning agents which cause surprising cleaning results without any special effort might often lead to long term damages.

Outside surfaces are not only exposed to weather, but also to the increased effects of smoke, industrial fumes and aggressive flying dust. Deposits of these substances combined with rain or condensation can impair surfaces and alter the decorative appearance. We recommend regular cleaning of the outside surfaces, depending on the degree of staining, in order to prevent long term settling of deposits. The sooner stains are removed from the surface, the easier their cleaning will be.

### 4.2. Hardware

All hardware parts are to be checked regularly for tight fitting and for wear and tear. If necessary, fixing screws need to be tightened or faulty parts need to be replaced by authorised personnel.

## 4. CLEANING, CARE AND MAINTENANCE

# Internorm®

Furthermore, all gliding parts and movable hardware parts have to be greased once per year (acid free grease or oil). Hardware should only come in contact with those care and cleaning agents that do not impede the corrosion protection of the hardware parts.



Particular care must be taken when cleaning electronic hardware parts (as e.g. the window control or the plug connection between sash and frame with electric blinds). These parts need, especially during the construction period, but also during regular use of the window, to be protected of soiling and need to be kept clean to avoid disruptions in signal transmission.

With the I-tech locking the corner drives are additionally secured with a pin (grub screw) which lies under the middle gasket. Due to the alternating load when locking the sash this pin can come out through the middle gasket and needs to be screwed in flush to the bottom of the gasket groove using a SW2.5 Allen key. Otherwise the window frame might get damaged.



### 4.3. Cleaning tips - glass surface

Dirty glass surfaces can be cleaned wet with water, sponge, cloth etc. Common glass cleaners without scouring agents may be added to the water. Persistent stains such as paints or tar droplets should be removed with methylated spirits, acetone or petroleum ether. The glass surface should then be cleaned wet again.

Metallic items (e.g. razor blades, steel wool ...) must not be used!



Do not use alkaline cleaning lye, acids or cleaning agents containing fluoride to clean the glass surface.



Protect the glass surface with suitable cover foils from

- plaster splatters, cement, untreated concrete surfaces, fibre cement boards
- flying sparks or welding beads from angle grinders
- acidic facade stone cleaners.

### 4.4. Gaskets

All gasket profiles have to be cleaned and greased at least once per year to retain functionality. We recommend the care product for gaskets. This care product for gaskets retains the pliability of the gasket and prevents it from becoming brittle prematurely. Please ensure the gasket profiles are not damaged and do not come into contact with solvents.

Generally gasket should only be cleaned with water and possibly a little bit of dishwashing liquid.



#### Permitted cleaning agents

- Alkaline cleaning agents (soapy solutions)
- Mixtures of water and alcohol

However, concentration, exposure time and ambient temperature play an important role. It could damage the material if the concentration of the cleaner is too high.

#### Prohibited cleaning agents

- Cleaners containing chlorine or cleaners with peroxides can damage the material over a longer period of time or it could lead to discolouration.
- Oils, greases, oil and grease containing substances and petrol can lead to a cracked and unsightly appearance.



## 4. CLEANING, CARE AND MAINTENANCE

# Internorm®

### 4.5. UPVC surfaces

Two sets of Internorm care products are available for cleaning UPVC surfaces. One cleaning agent is especially suitable for hard UPVC surfaces and the other one for designer surfaces. Especially avoid aggressive and dissolving cleaning agents and avoid direct sunlight during cleaning on the areas which need to be cleaned.



Intensive cleaner    Decor cleaner

### 4.6. Timber surfaces for timber/aluminium elements

We recommend using mild cleaning products, such as diluted washing-up liquid or soapy water, to clean inside timber surfaces. As timber surfaces on the inside are not exposed to weather (wear through rain and sunlight), coating is not necessary.

Avoid scouring, acidic and solvent cleaning products. Only use soft cleaning cloths to avoid scratching the paint surface.

Window cleaners contain small amounts of alcohol and ammonium chloride. These products are well-suited to clean glass panes, as well as timber frame profiles. Dry the timber profile thoroughly after cleaning with a dry, soft cloth, as alcohol applied to the paint surface for too long, can dissolve it.

### 4.7. Anodised or powder coated aluminium surfaces

Anodising and powder coating are considered refinements of exterior aluminium surfaces which are especially durable and decorative. In order to retain the decorative appearance of these construction parts for decades and to reduce corrosion impact, the surfaces need to be looked after at least twice per year with adequate cleaning and surface conservation products.

Depending on the degree of staining (strong stains) care and cleaning intervals should be shortened accordingly.

In the outsourced cleaning and care of buildings, processes according to the current quality guidelines for facade cleaning (GRM) are necessary.

### 4.7.1. Requirements and process for cleaning aluminium surfaces

#### Object conditions

Do not clean surfaces in direct sunlight. The surface temperature must not exceed 25° C. Use suitable cloths for cleaning, which do not scratch the surface. Refrain from tough scrubbing.

#### Pre-cleaning

Before applying special cleaning or conserving products, existing stains should be removed in a pre-cleaning process. Use only clean water for this, possibly with small amounts of neutral cleaning agents (only pH neutral cleaning agents with a pH value between 5 and 8) e.g. washing-up liquid in normal concentration. These cleaning products should not be warmer than 25° C. Do not use steam cleaners.

#### General cleaning

General cleaning is necessary if persistent stains are present or when elements have not been cleaned for a long time. Special abrasive cleaning agents should be used for these.

**Eloxal Clean for anodised** aluminium surfaces

**Powder Clean for powder coated** aluminium surfaces

These general cleaning products should only be used after a successful pre-cleaning process. After the general cleaning process, treatment with the recommended conservation agents is necessary.

#### Conservation

Conservation agents are used to apply a film with temporary stain and water repellent effect to anodised or coated aluminium parts, which also improves the

decorative appearance of the surface.

The conservation has to be renewed from time to time.

**Eloxal Polish Cleaner for anodised** aluminium surfaces

**Powder Polish Cleaner for powder coated** aluminium surfaces

Conservation agents should only be applied after a successful pre-cleaning process.

### 4.7.2. Cleaner for anodised surfaces

When cleaning very dirty anodised surfaces, do not use scratching or scouring products. Persistent stains such as tar, laquer or similar compounds can also be removed with solvents, e.g. benzine or cellulose thinner (only for local application and with corresponding subsequent treatment). Observe the respective safety and handling instructions for each product. Gaskets or painted surfaces must not come in contact with these products.

#### 4.7.2.1 General cleaner for anodised surfaces

This general cleaning agent is an acid and alkaline free intensive cleaner for slightly to strongly stained anodised aluminium surfaces. It contains small abrasive particles, adapted to the anodised surface, grease solvents and a combination of other cleaning additives.

The Eloxal Clean general cleaner is supplied as paste. Eloxal Clean is specifically characterised by its intensive cleaning effect without fear of damaging the anodised surface.

#### Application range

For abrasive first cleaning.

For abrasive general cleaning.

For slightly to strongly stained outside facades of anodised aluminium.

## 4. CLEANING, CARE AND MAINTENANCE

# Internorm®

### Cleaning instructions

Apply Eloxal Clean to a damp cloth, fleece or sponge and rub with evenly applied pressure on to the anodised surface. Only treat one section at a time. Rinse the cloth, fleece or sponge in between. The time spent and the pressure applied depends on the intensity of the staining.

After the cleaning process rinse off the anodised surface thoroughly with clean water, until all residue is removed.



### 4.7.2.2 Conservation agent for anodised surfaces

#### Eloxal Polish Cleaner

This cleaning and conservation agent is a care product on emulsion basis.

#### Application range

The Eloxal Polish Cleaner and Conservation agent is used for slightly stained anodised aluminium surfaces, which - for decorative reasons - should be cleaned several times each year.



### Cleaning instructions

Shake bottle well before use. Apply Eloxal Polish Cleaner thinly with a soft cloth and over a large surface. Slight stains, as well as dark anodised elements should be evened out with polishing movements.

### 4.7.3. Cleaning of powder coated surfaces

Solvent containing acidic and alkaline cleaning agents affect the surface of powder coatings and must not be used; the same applies to scratching or scouring cleaning agents.

In order to remove persistent, greasy, smeary stains we recommend cleaning benzine or isopropyl alcohol (IPA). Leave it on the surface only for a short time and rinse off with clean water.

## 4. CLEANING, CARE AND MAINTENANCE

# Internorm®

### 4.7.3.1 General cleaner for powder coated surfaces

#### **Powder Clean**

This general cleaning agent is an intensive cleaning agent for chalky and strongly stained powder coated aluminium surfaces. It contains small abrasive particles, adapted to the powder coated surface, grease solvents and a combination of other cleaning additives. It is supplied as paste. Only use Powder Clean general cleaner in combination with subsequent conservation products.



#### **Application range**

For abrasive removal of chalking.

For strongly stained powder coated aluminium surfaces.

#### **Cleaning instructions**

Apply Eoxal Cream to a damp cloth, fleece or sponge and rub with evenly applied pressure on to the surface. Only treat one section at a time. Rinse the cloth, fleece or sponge in between. The time spent and the pressure applied depends on the intensity of the staining.

After the cleaning process rinse off the powder coated surface thoroughly with clean water, until all residue is removed.

### 4.7.3.2 Conservation agent for powder coated surfaces

#### **Powder Polish Cleaner**

This cleaning and conservation agent is a care product on emulsion basis.

#### **Application range**

The Powder Polish Cleaner and Conservation agent is used for the general cleaning process of newly fitted powder coated, as well as for slightly stained powder coated aluminium surfaces, which - for decorative reasons - should be cleaned several times each year.



### **Cleaning instructions**

Shake bottle well before use. Apply Eloxal Polish Cleaner thinly with a soft cloth and over a large surface. Slight stains, as well as dark anodised elements should be evened out with polishing movements. Powder coated surfaces that have already started chalking must first be cleaned with Powder Clean.

### **4.8. Cleaning instructions for stainless steel**

Stainless steel is used in the building industry primarily where aesthetics and hygiene are the main focus.

As it cannot be avoided that a rust film or flash rust may deposit on the surface, this often leads to the erroneous assumption that stainless steel has rusted.

We recommend treating surfaces with visible stains or corrosion using standard stainless steel cleaners. These can be obtained in respective specialist shops.

### **4.9. Care and maintenance of the I-tech ventilation system**

The ventilation system should be regularly checked and maintained. Free up machine from dirt and check clamping screws for tight fitting. Test the ventilation system with the test run. Maintenance and repair of parts inside the ventilation housing are to be carried out exclusively by authorised personnel. Opening of the ventilation housing which lies under the cover leads to loss of warranty and exclusion of liability.

Please use a soft, slightly damp cloth to clean the housing parts and the ventilation grid. Please do not use corrosive chemicals, aggressive cleaning solutions or solvents to avoid damages to the surface. Protect your ventilation system permanently from water and dirt.

### 4.10. Special warning for timber/aluminium elements

Natural timber always tends to adapt to its surrounding humidity. This characteristic remains the same throughout the entire life cycle, from the living tree to the processed timber element. Protect your windows especially during the construction period from excess construction humidity. This applies especially to winter construction sites, where large amounts of water occur due to plastering and screed works in closed buildings. Ensure sufficient ventilation during the construction period. Too high humidity over a longer time period can lead to swelling of timber profiles and cause severe damage on corner connections and surfaces. As a general guideline, you can simply compare your windows with the ones depicted below and assess whether the construction humidity and therefore the moisture in the timber is alright.

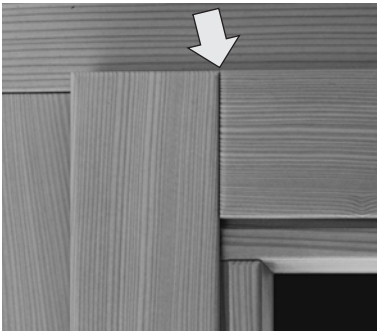

Flush top and bottom corner connections guarantee that the moisture in the timber is in the permitted standard range.

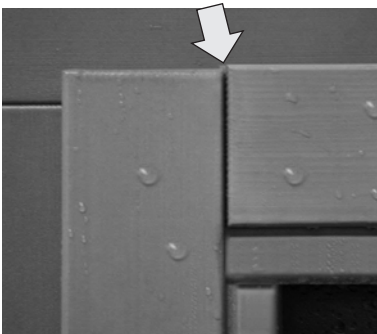

Horizontal timber elements are not flush in the corner connections and therefore project. This is a clear indication that the timber elements have swollen up due to excess moisture. Ensure sufficient ventilation and dry out the timber elements!

## 5. COMFORT

Not only the room temperature and humidity in the air determine how comfortable and cosy a room appears.

The temperature difference between room air and surfaces enclosing the room, as well as the corresponding radiation asymmetries and air movements (room air turnover), are also related to this.

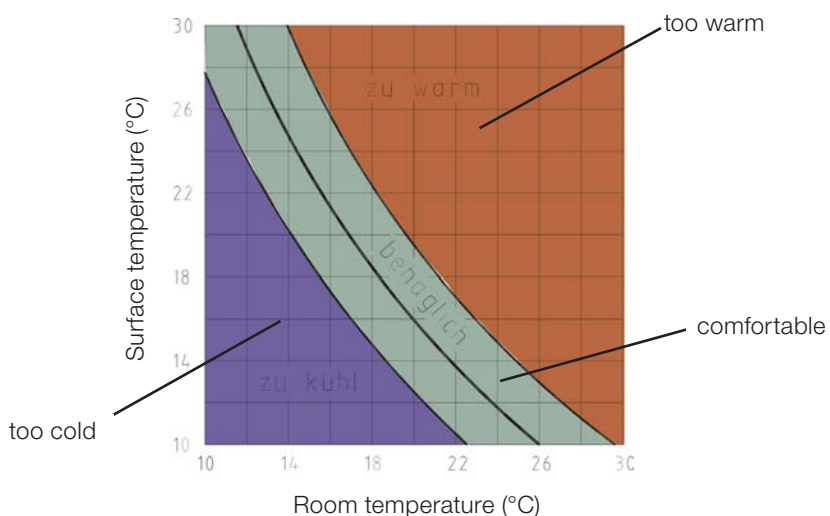

Example: If the wall surface has a temperature of 18° C and the room air temperature is 20° C, an average person will feel more comfortable than with a wall temperature of 15° C and an air temperature of 24° C. This means that the temperature difference between room air and enclosing surfaces should not exceed 2° C.

In rooms with relatively large temperature differences between walls and room air, the warm air cools down at the walls, sinks down to the floor, and results in a pool of cold air. This constant air movement results in the impression of a draught (room air turnover).

Therefore, good thermal insulation of the enclosing surfaces is important!



## 6. AIRING

The minimum oxygen demand for humans is approx.  $1.8\text{m}^3/\text{h}$  per person. In order to accommodate pollutants and odours, the amount of fresh air needed hygienically is 10 to  $25\text{m}^3/\text{h}$  per person.

The amount of air inflow necessary to get moisture out depends on the amount of occurring moisture, the indoor climate, the outdoor climate and the size of the room.

People in living and work spaces create water vapour. The occurring water vapour originates from the breath of the present people, evaporating from watering flowers, bathing, showering, cooking and similar processes.

The amount of water vapour that may occur is demonstrated in the explanation below.

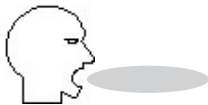

Breathing air:  
Daily 1-2 litres of water

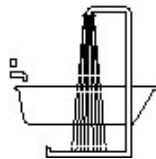

Bathing, washing,  
laundry, watering  
flowers: Daily up to 3  
litres of water in a 3  
person house hold

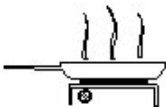

Cooking:  
Daily up to 2 litres of water  
in a 3 person household



The humidity rises  
further if laundry is hung  
up to dry in the room.

Therefore, a 3 person household accumulates approx. 180 litres of water per month; this is more than one bathtub full of water.

If the water cannot get outside sufficiently through airing, the humidity level in the air rises, which leads to condensation and can then lead to mould.

### Airing – but correctly!

Internorm windows have very good thermal insulation characteristics and good impermeability. This protects you from bothersome draughts, cuts down on heating costs and keeps out disturbing noise. However, it also necessitates more conscious airing.

Correct airing is immensely important. It assures a constant oxygen supply for breathing air as well as carrying off pollutants which accumulate when aired insufficiently. Furthermore, with correct airing you can avoid condensation as well as the danger of mould developing.

#### Which airing options are there?

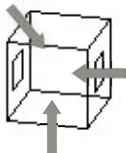

Self-airing:  
„Airing“ with closed windows and doors due to permeability of the building shell.

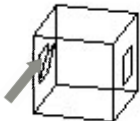

Constant airing:  
Constantly slightly opened windows due to gap ventilation or via tilt hardware.

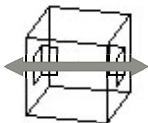

Maximum airing for a short time:  
Airing with fully open windows on opposite sides of a room.

It is recommended to carry out maximum airing for 5 minutes several times during the day.

This is most effective if windows on opposite sides of the room can be used for airing.

This maximum airing, several times a day, will ensure the desired air exchange and take out humidity without affecting the comfort. The room temperature will fall for a few minutes, but the „heat storage“ in walls, ceiling and floor will cool down only minimally in this short time. The fresh air will heat up again quickly, energy loss is minimal.

### What do I need to know?

Air exchange through the gaps in closed windows is not sufficient for adequate reduction of humidity and hygienically necessary fresh air supply.

Depending on usage of the room and on the amount of produced humidity it is recommended to ensure air exchange through constant airing or maximum airing for a short time.

Transporting humidity into cooler rooms within the building should generally be avoided. If this is not possible, please take this into consideration when airing.

In rooms with open fireplaces (boilers, open fireplaces, oil stove, gas stove etc.) a constant supply of fresh air must be ensured.

Construction moisture leads to increased strain on the window profiles. In order to avoid surface damage or swelling of timber profiles, ensure sufficient airing!

Under extreme demands, e.g. in wet rooms, indoor swimming pools or rooms with chemicals, adapted heating and ventilation systems might become necessary.

## 7. WARRANTIES

Internorm provides the following services and warranty rights for the end customer:

---

10 year warranty on weather resistance against unnatural change of colour and cracks in surfaces of white UPVC window and door profiles, except for mitre cracks. When assessing weather resistance, the change in colour, according to test system corresponding to DIN EN 513, must not be greater than level 3 on the greyscale according to DIN EN 20105-A02.

There is no warranty on the change of appearance of surfaces as a result of dirt.

---

10 year warranty on weather resistance against unnatural change of colour and cracks in surfaces of inside foil covered UPVC window and door profiles, except for mitre cracks. When assessing weather resistance, the change in colour, according to test system corresponding to DIN EN 513, must not be greater than level 4 on the greyscale according to ISO 105-A02. There is no warranty on the change of appearance of surfaces as a result of dirt.

---

10 year warranty on weather resistance against unnatural change of colour and cracks in surfaces of anodised or powder coated aluminium window and door profiles.

Minimum value for remaining gloss is the gloss level determined according to DIN EN ISO 2813, which is at least 30 % of the original value.

Exempt from this warranty are corrosions due to environmental impacts, such as fitting window and door elements close to the sea (salt in the atmosphere), close to roads with gritting or in an atmosphere polluted with heavy industry pollutants.

There is no warranty on the change of appearance of surfaces as a result of dirt.

These warranties only apply to surfaces listed in the Internorm aluminium colour fan, the Internorm RAL colour fan or the Internorm hirest colour fan.

---

---

## 7. WARRANTIES

**Internorm®**

10 year warranty against condensation between the panes of insulating glass. The guidelines applied for general visual assessment of mirrored insulating glass are those of the Federal Guild Association of the Glazing Trade Hadamar or Ö-Norm B3738.

Condensation on both sides of single glazing or on the room and/or weather exposed side of insulating glass are exempt. This condensation is due to physics and may occur under certain climatic conditions.

---

10 year warranty on the glue connection of glued Georgian/feature bars.

---

10 year warranty on the function of the material compound timber, thermal foam and aluminium profiles in HF 300 (EDITION), HV 340 (EDITION 4), HF 200 (VARION), HV 240 (VARION 4) and FUSION when adhering to the Internorm fitting and maintenance guidelines.

---

10 year warranty on the function of the glued connection and sealing of the insulating glass panes with window profiles in HF 300 (EDITION), HV 340 (EDITION 4), HF 200 (VARION), HV 240 (VARION 4) and FUSION when adhering to the Internorm fitting and maintenance guidelines.

---

5 year warranty for PVD coated entrance door handles against corrosion, if no mechanical damages are apparent.

---

5 year warranty on weather resistance against unnatural colour changes or cracks in door filling surfaces. There is no warranty on the change of appearance of surfaces as a result of dirt.

---

3 year warranty on weather resistance against unnatural change of colour and cracks in surfaces of UPVC roller shutter profiles. When assessing weather resistance, the change in colour, according to test systems corresponding to DIN EN 513, must not be greater than level 3 on the greyscale according to DIN EN 20105-A02. There is no warranty on the change of appearance of surfaces as a result of dirt.

---

3 year warranty on weather resistance against unnatural change of colour and cracks in surfaces of anodised or powder coated aluminium roller shutters, blinds and window shutter profiles. Minimum value for remaining gloss is the gloss level determined according to DIN EN ISO 2813, which is at least 30 % of the original value. Exempt from this warranty are corrosions due to environmental impacts such as fitting window and door elements close to the sea (salt in the atmosphere), close to roads with gritting or in an atmosphere polluted with heavy industry pollutants. There is no warranty on the change of appearance of surfaces as a result of dirt.

---

3 year warranty in the function of window and door hardware when adhering to the Internorm fitting and maintenance guidelines.

---

30 years provision warranty from construction year 1999

Furthermore, Internorm guarantees that Internorm products can be repaired by our specialists in such a way that their full functionality is guaranteed to exist or be retained over a time period of 30 years. However, this is subject to the construction (= frames and sashes) being undamaged. The 30 year period begins with the Internorm production date. The services or materials, labour time etc., necessary to retain functionality will be charged at respective current rates.

---

### 7.1. General information

Faults of any kind are to be brought to the attention of your Internorm partner immediately after receipt of the goods.

All delivered goods are to be examined thoroughly upon receipt. With faults of any kind, further processing is only possible after prior written communication with the Internorm partner subsequent to his explicit agreement to further fitting of these elements.

Warranties become invalid if surface damages have been caused with intent or out of negligence or by neglecting the necessary care. This applies especially to strongly stained or difficult to remove, persistent stains.

Warranties are also invalid if damages or functionality disturbances are due to unprofessional fitting or caused by other construction parts (e.g. roof, subsidence of construction parts).

Warranty claims are to be made immediately - which is otherwise subject to exclusion - by the end customer, but at the latest by the deadline indicated in the warranty certificate. The claim has to primarily be made with the Internorm partner that has delivered the items to the customer. If this is not possible, the warranty claim has to be made with the official Internorm office in the country in question. Warranty claims have to be made in writing.

It should be noted that the warranty for functionality of the product generally presupposes that the Internorm fitting and maintenance guidelines have been adhered to completely and especially assembly and fitting have been carried out completely professionally.

In sales and manufacturing contracts, the deadlines indicated in the warranty certificate generally begin with the date on which Internorm has delivered the products. If fitting is carried out by an authorised Internorm partner, the warranty period, as an exception, begins with the end of the fitting works (according to the business journals of the Internorm partner).

Driving times, material and labour costs as well as any other additional charges by Internorm are included in the warranty. The warranty is valid if Internorm is chosen for the complete or partial replacement of the product or for repair or improvement works. Further subsequent damages and costs are not subject to the warranty (e.g. writing applied by the customer to a glass element to be exchanged according to the warranty; also there is no compensation for the loss of income or earnings or inability to use the rooms included in the warranty works, etc.). Warranty services are delivered free.

Sales items (meaning with reduced prices), indicated on the invoice as such, are not subject to any warranties.

### 7.2. Fitting advice

All hardware versions are equipped with „fine adjustments“. These fine adjustments are to be carried out as part of the fitting service provided by the fitting company. The Internorm fitting and adjustment guidelines are to be adhered to in each case, especially for self-fitting.

Any subsequent necessary adjustment works, maintenance or changes to the product must be charged.

Faults in fitting and any faulty functions resulting thereof are to be covered by the respective fitting company and are not part of Internorm warranties.



### 7.3 Technical limitations of the warranty

The warranty applies as long as the usual loads stated in common technical standards are not exceeded. If the product is used in an unusual way, no part of the warranty applies.

The above mentioned warranty services only refer to the respective single element in question. If two or more single elements are connected to form continuous window/door surfaces, a separate approval by Internorm is necessary. Apart from this, all warranties are rendered invalid, if the connection of single elements is not carried out professionally and does not comply with technical standards.

Surface damages caused by aggressive or scouring cleaning agents are exempt from the warranty. Internorm recommends regular cleaning with the Internorm care set.

Surface changes caused by chemical reactions (e.g. zinc particles, leachates from the facade [cement asbestos or other] and cement asbestos windowsills) on white UPVC profiles and on powder coated or anodised surfaces are exempt from the warranty.

There is no warranty on the change of appearance of surfaces as a result of dirt.

Different colour changes in different elements caused by the fitting location between elements exposed to weather (e.g. south-facing) and elements in protected position (e.g. north-facing) are exempt from warranty.

For timber elements it is explicitly indicated that aggressive cleaning agents (containing ammonium chloride, alcohol, as well as acidic or scouring cleaning agents) will damage the timber surface. Timber elements are to be regularly checked for damages (hail damage, natural cracks in timber, scratches etc.) and possibly mended for short term according to the Internorm maintenance guidelines.

The surface warranty does not apply to fitting material.

Condensation on glass surfaces:

Under certain conditions water condensation may occur on the outer glass surface of insulating glass on the inside or the weather-exposed side.

On insulating glass with especially high thermal insulation temporary condensation may also occur on the weather-exposed side, if the outside humidity (relative air humidity outside) is very high and the air temperature is higher than the temperature of the pane surface. With especially extreme temperature differences, icing over may also occur. This can be solved by shading the window and door elements (e.g. with roller shutters, projecting roofs etc.).

Condensation on the glass in composite windows is exempt from the warranty as, for physical reasons, under certain climatic conditions, condensation might form in the space between the panes (where the optimum sun protection is).

The wetting properties of glass surfaces on the outside of insulating glass may be differing due to e.g. marks from rollers, fingers, labels, paper structure, vacuum suckers, sealing remains, smoothing agents, sliding agents or environmental impact. On wet surfaces due to rain, dew or cleaning water, differing wettability may be observed. Therefore, these marks do not represent defects.

### 7.4. Remarks concerning CE labelling

Each element is labelled with a CE test sticker. This is situated in the frame rebate or with fixed glazing elements under the glazing bead. Multi-part constructions are only labelled once.

With the printed code on this label, you can retrieve technical data of your element on the internet at: „[www.internorm.com](http://www.internorm.com)“.



